

SALICE



Tilt

*system for flap doors
with upward or
downward opening*

ENG



Tilt

Compact design, timeless elegance.

- Concealed mechanism for flap doors
- Available for upward or downward opening
- Compact design with a thickness of only 12 mm, 13.5 mm with cover
- Three mounting solutions: external with cover, recessed into the cabinet side, flush-mounted with cover
- For wooden doors with a thickness starting from 18 mm
- Minimum side panel thickness: 18 mm for the flush recessed version
- 3-way door adjustment for precise alignment
- Adjustable and decelerated opening and closing movement
- Wide range of covers available in different finishes



Tilt

Compactness and versatility.

Discreet, compact and essential, Tilt is the mechanism for flap doors that combines design, precision and versatility. It delivers high-level performance with extreme compact dimensions.

Designed for wooden doors and side panels starting from 18 mm thickness, Tilt offers maximum application flexibility with three mounting options: external with cover, recessed into the cabinet side, and flush recessed with cover. Solutions developed to meet different construction and aesthetic requirements, always ensuring an elegant and discreet result.



Tilt

Precision and elegance.

The 3-way door adjustment ensures precise alignment and long-lasting stability. The possibility to calibrate the spring force allows the opening and closing movement to be optimized, providing smooth, controlled and customizable motion.

The covers, available in several elegant finishes, allow perfect aesthetic integration with the cabinet.





Tilt Up

*system for flap doors
with upward opening*

Tilt Up

System for flap doors with upward opening



Technical information

System for upward-opening flap doors, side panel fixing, with external, recessed or flush assembly.

Decelerated closing.

Version for doors with thickness from 18 to 30 mm:
machining depth on the door 15 mm.

80° opening with opening limiter.

95° opening with opening limiter disengaged.

"K" drilling on the door 11 mm.

External assembly with cover

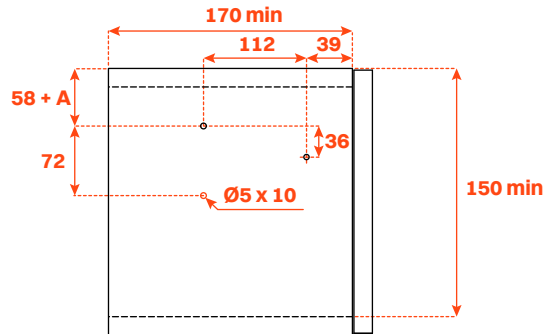

Recessed assembly in counter side panel



Counter side panel machining

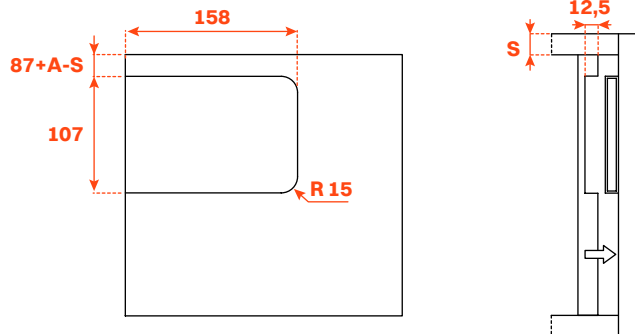

Required space for door opening

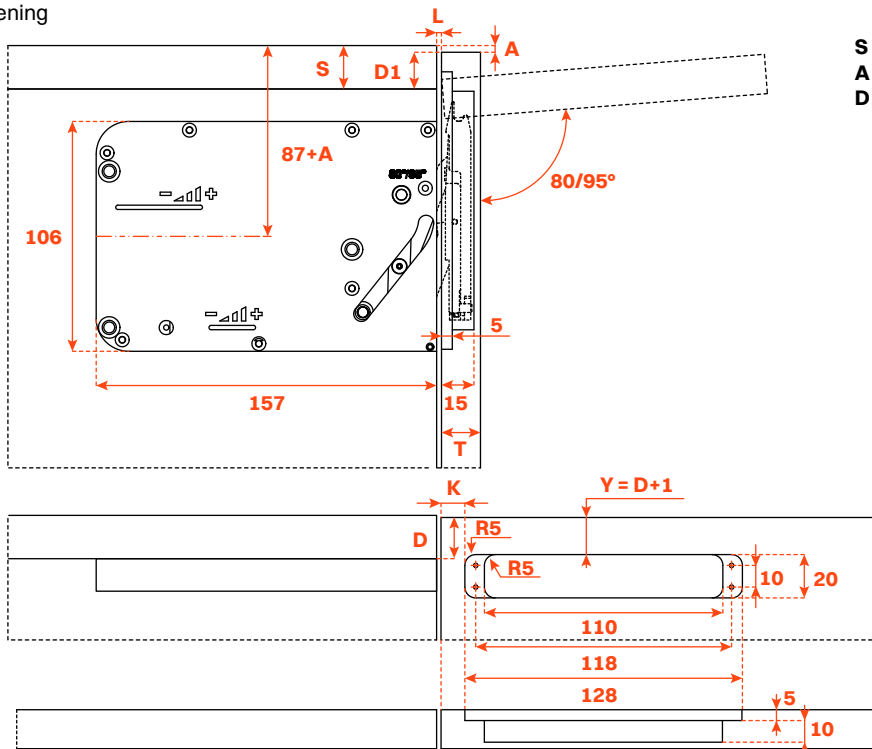

S max = 30
A min = 1
D1 = S - A

Flush recessed assembly with cover

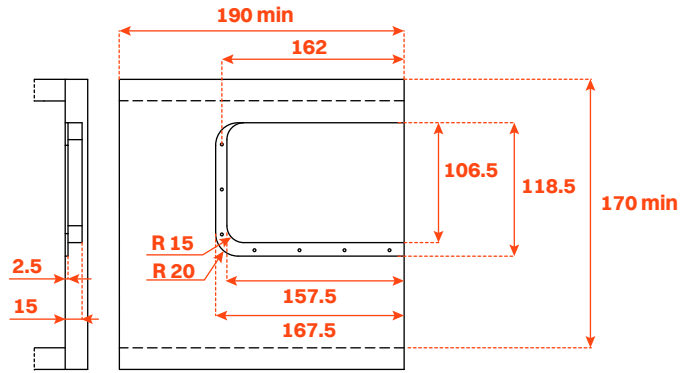

Required space for door opening

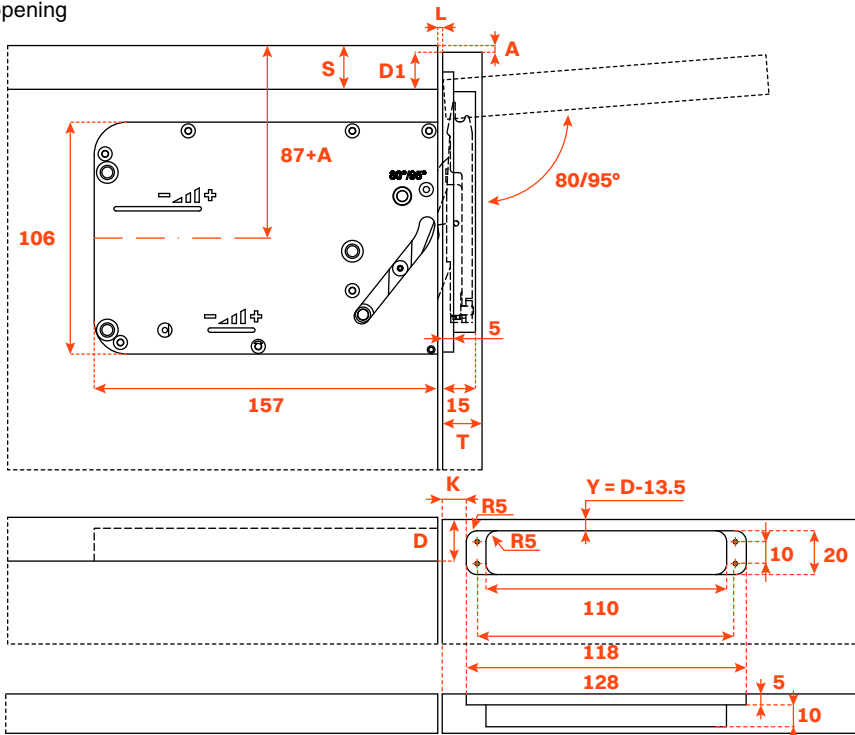

Construction with 2 overlapped systems.

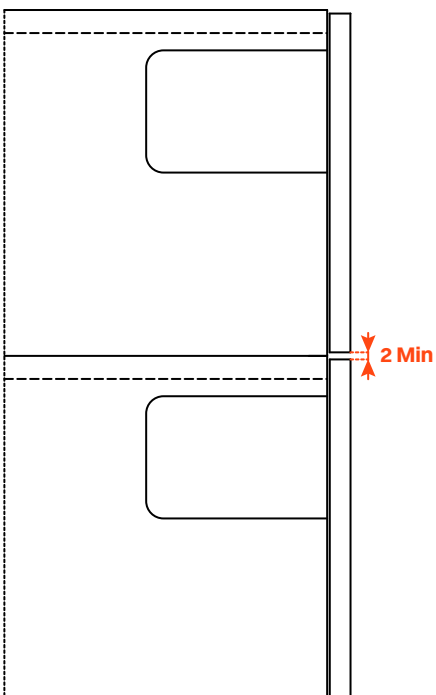

Construction with protruding top.

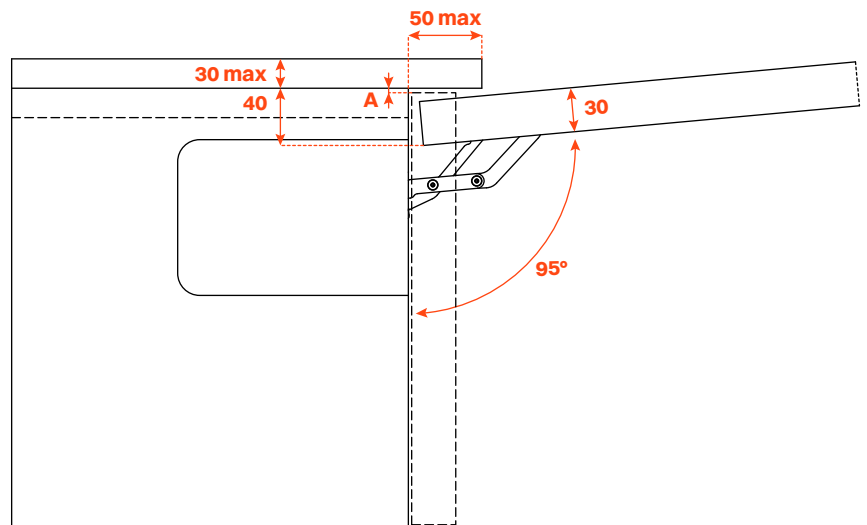

With $A = 1$ mm, the maximum top projection is 50 mm and the maximum door thickness is 30 mm.

Tilt Up

System for flap doors with upward opening

Mechanism assembly

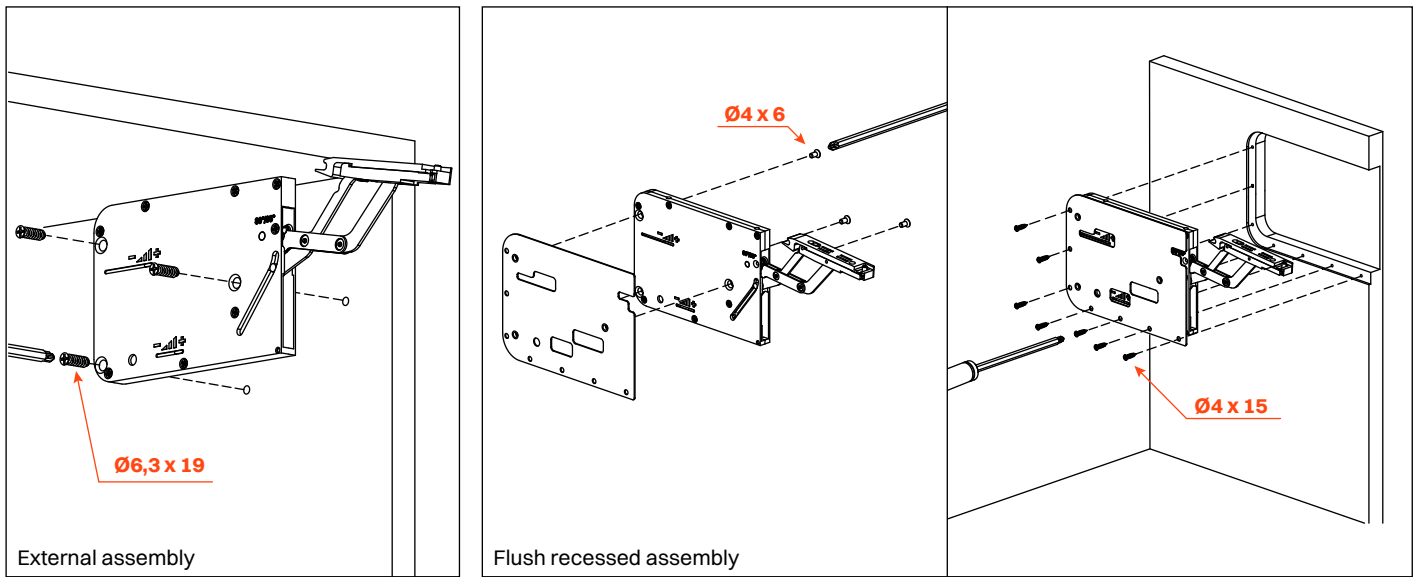

Door fixing bracket fastening

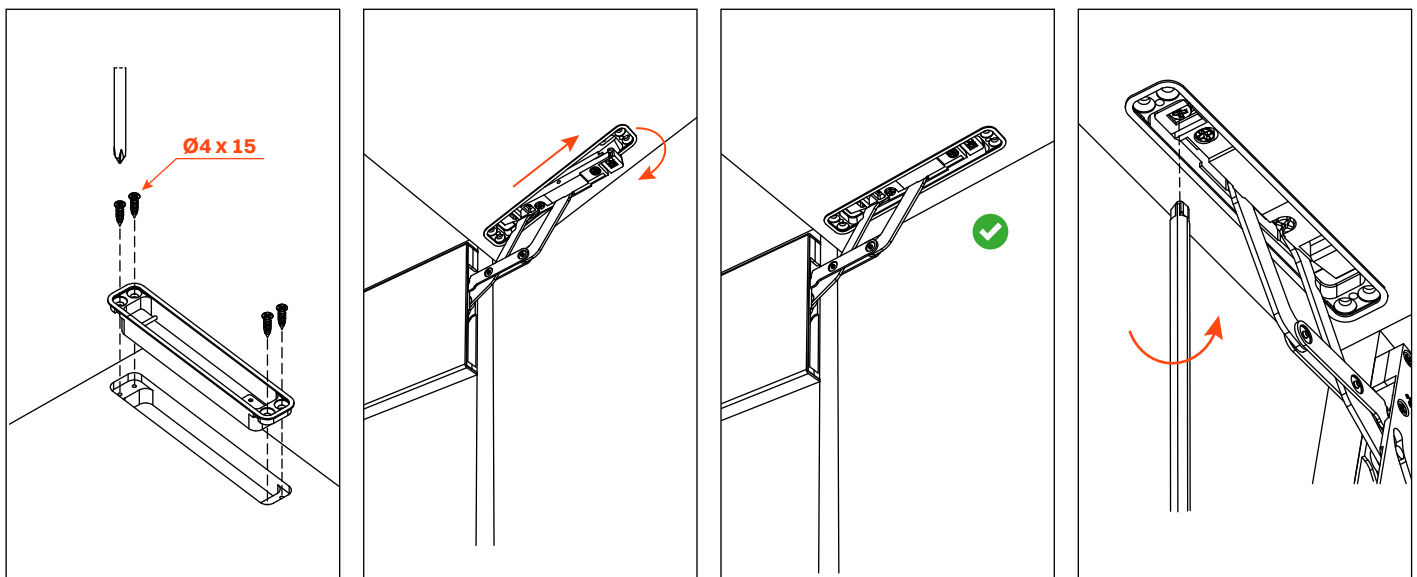

Removal of the 80° opening limiter

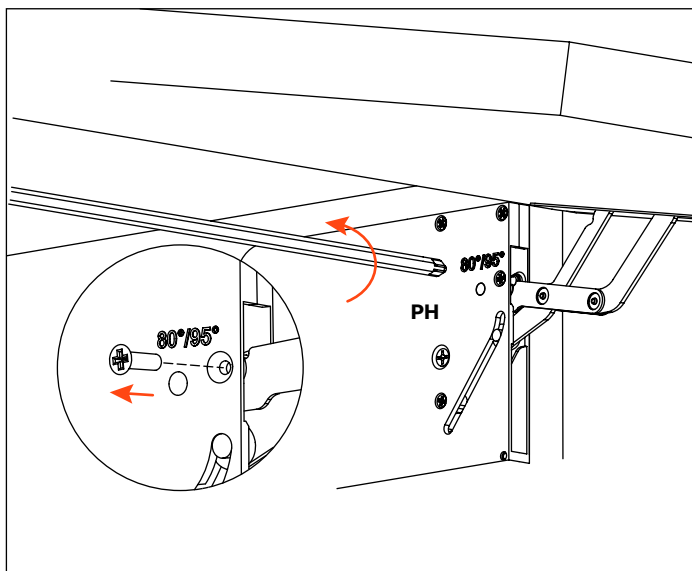

Door fixing bracket cover fastening

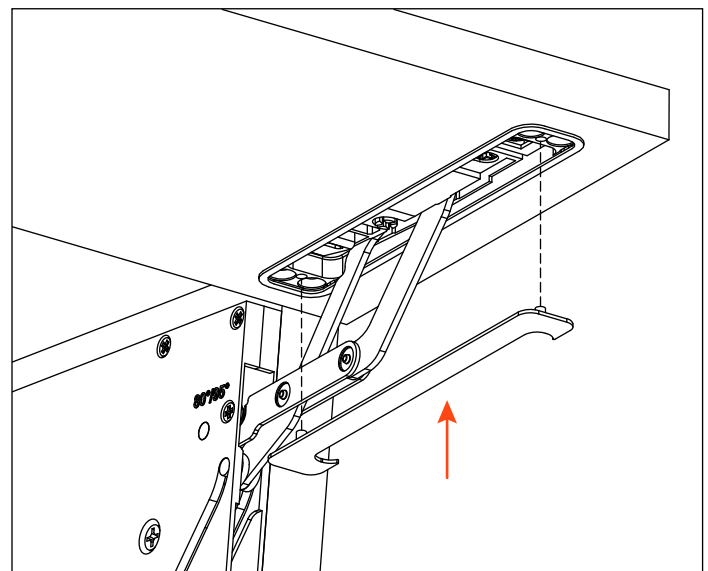

External cover assembly

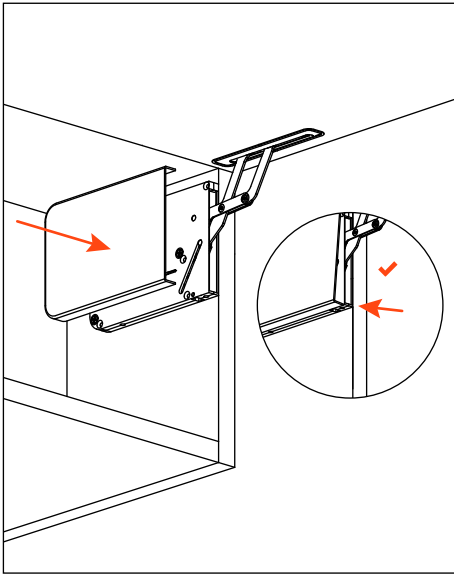

Counter side panel assembly

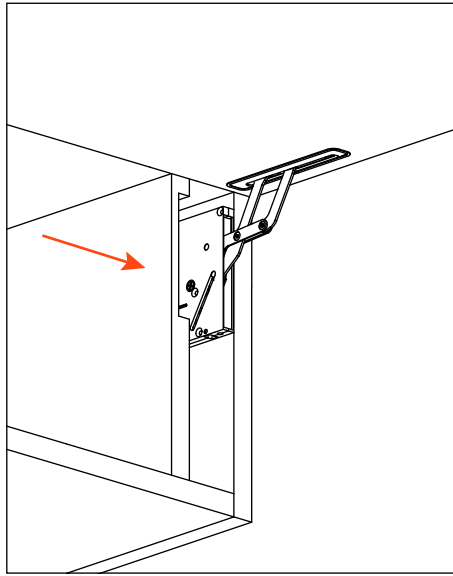

Flush cover assembly

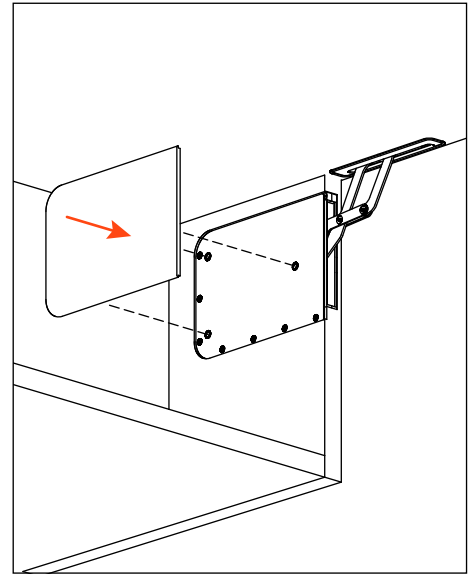

Spring adjustment

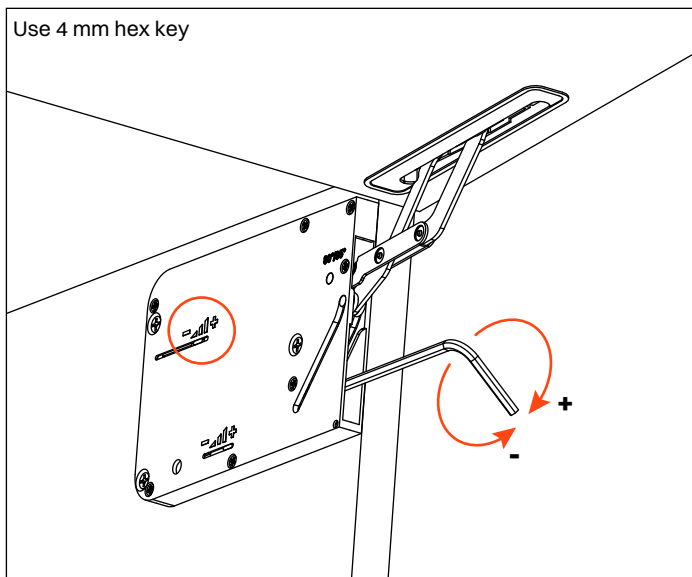

Decelerating force adjustment

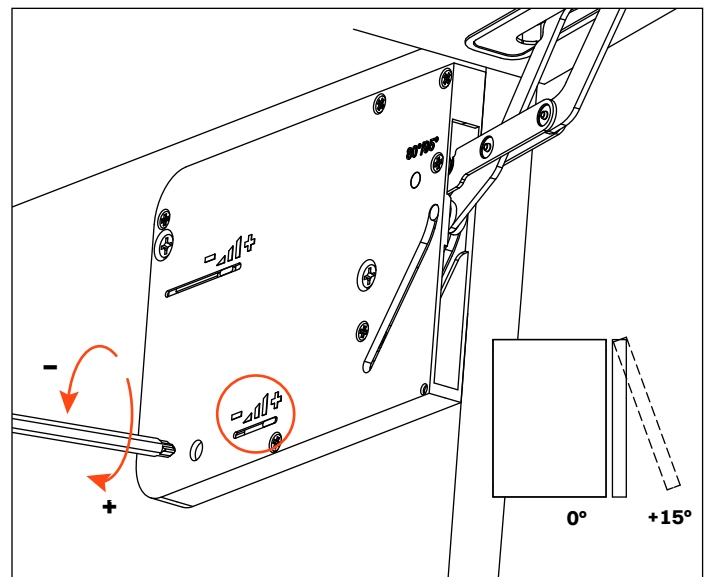

Height adjustment

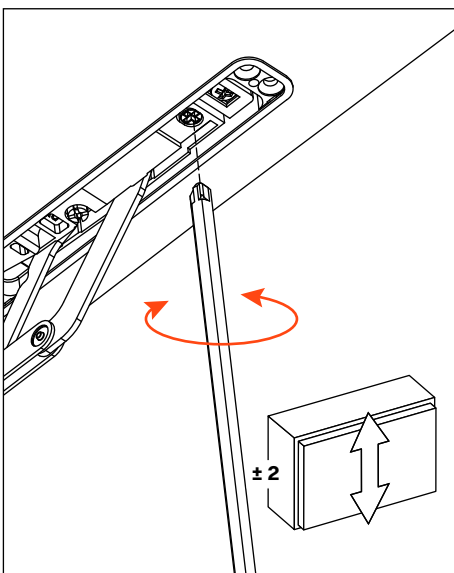

Sideways adjustment

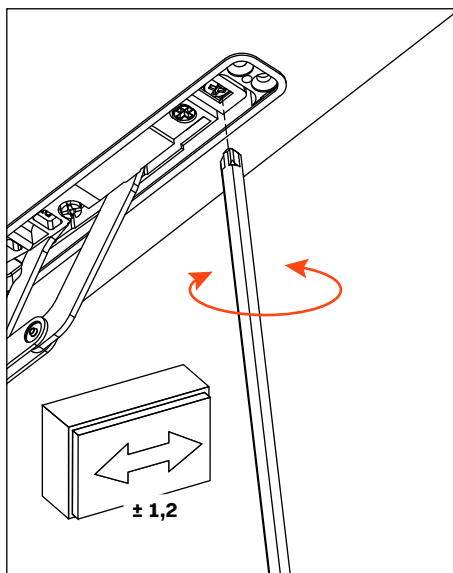

Depth adjustment

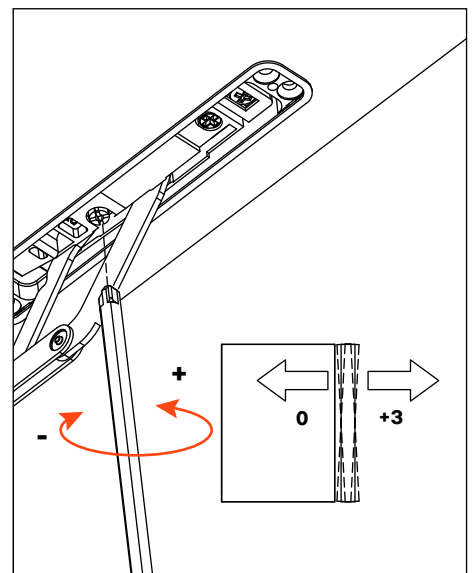

Tilt Up

System for flap doors with upward opening

Charts to determine the spring strengths according to the door weight and height.

Strength 1

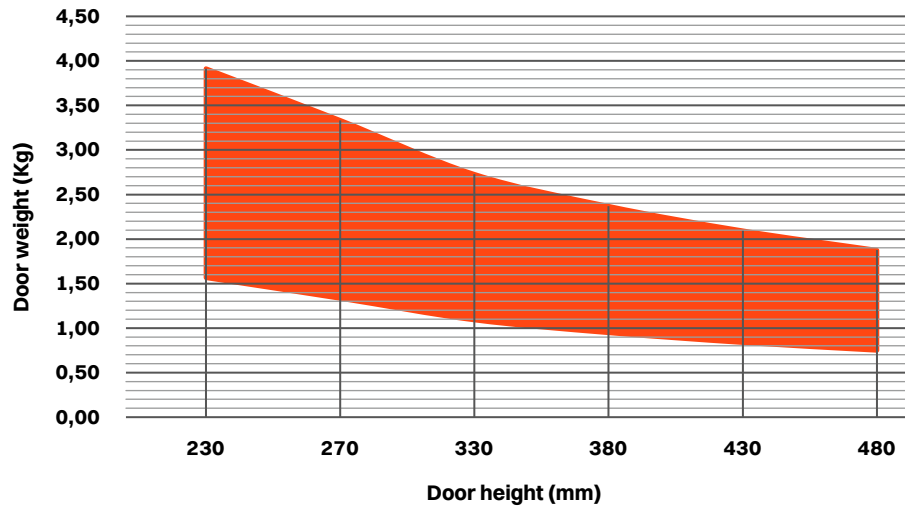

Strength 2

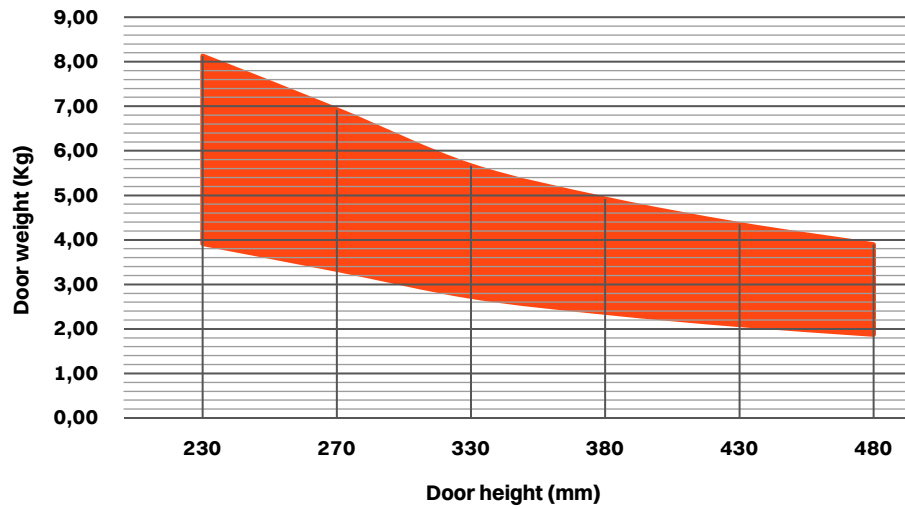

Strength 3

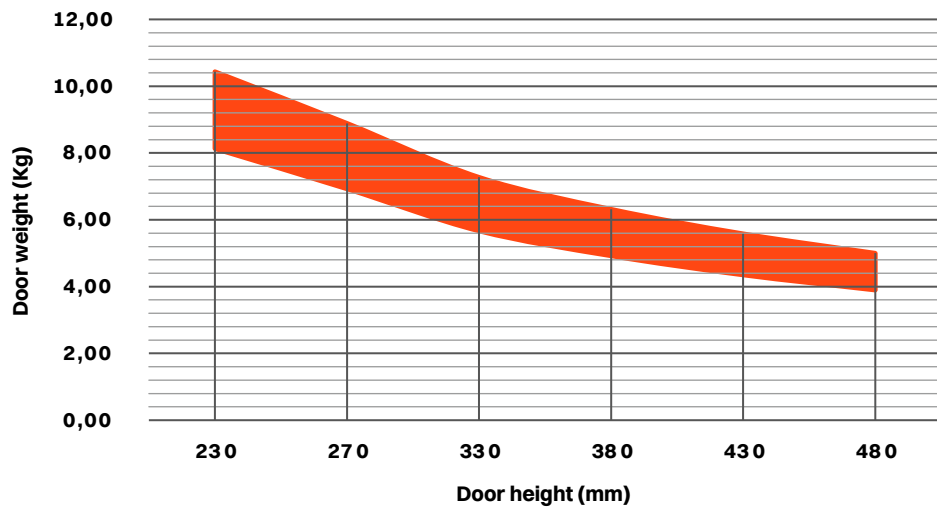

Strength 4

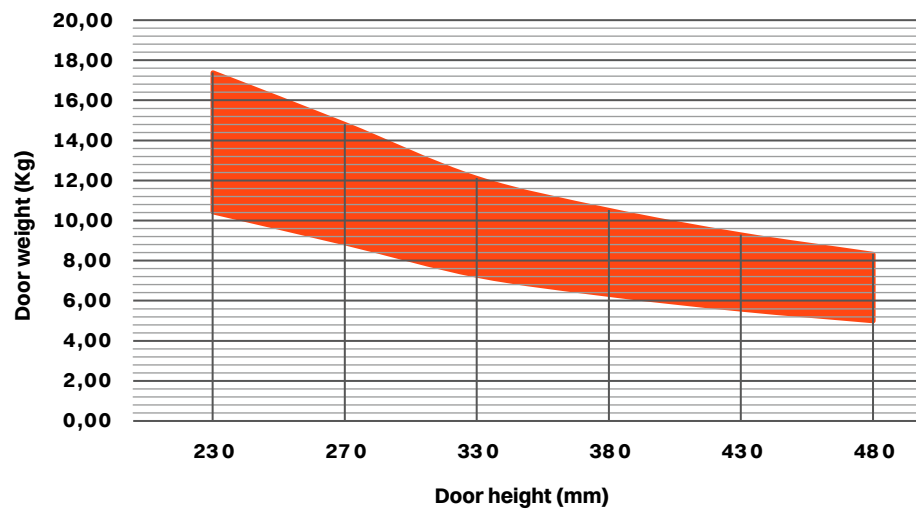





Tilt Down

*system for flap doors
with downward opening*

Flush recessed assembly with cover

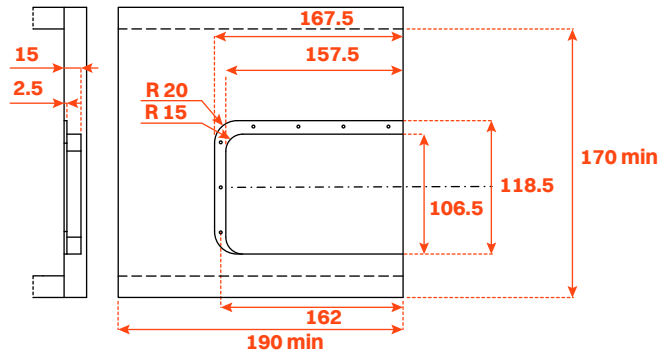

Required space for door opening

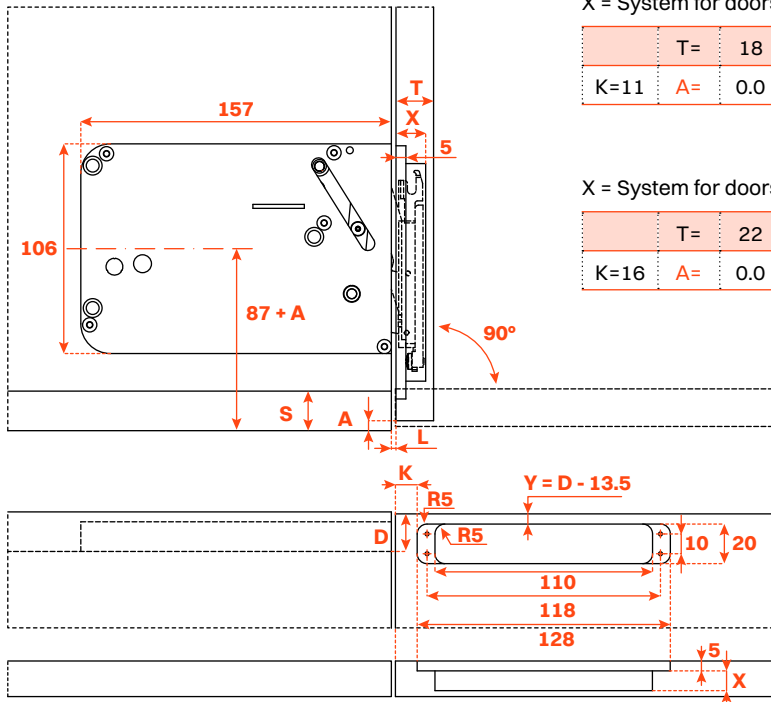

X = System for doors from 18 mm to 22 mm (X = 10 mm)

T=	18	19	20	21	22	
K=11	A=	0.0	0.0	0.0	1.0	2.0

X = System for doors from 22 mm to 30 mm (X = 15 mm)

T=	22	23	24	26	28	30	
K=16	A=	0.0	0.0	0.0	0.0	2	4

Tilt Down

System for flap doors with downward opening

Mechanism assembly

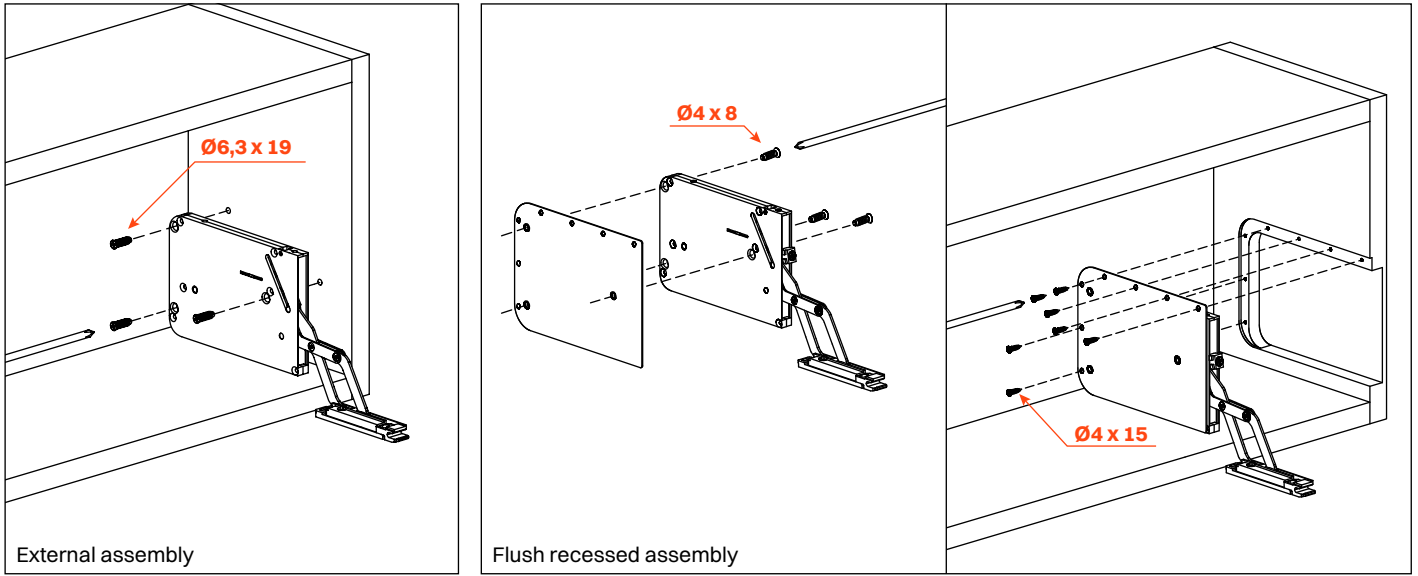

Door fixing bracket fastening

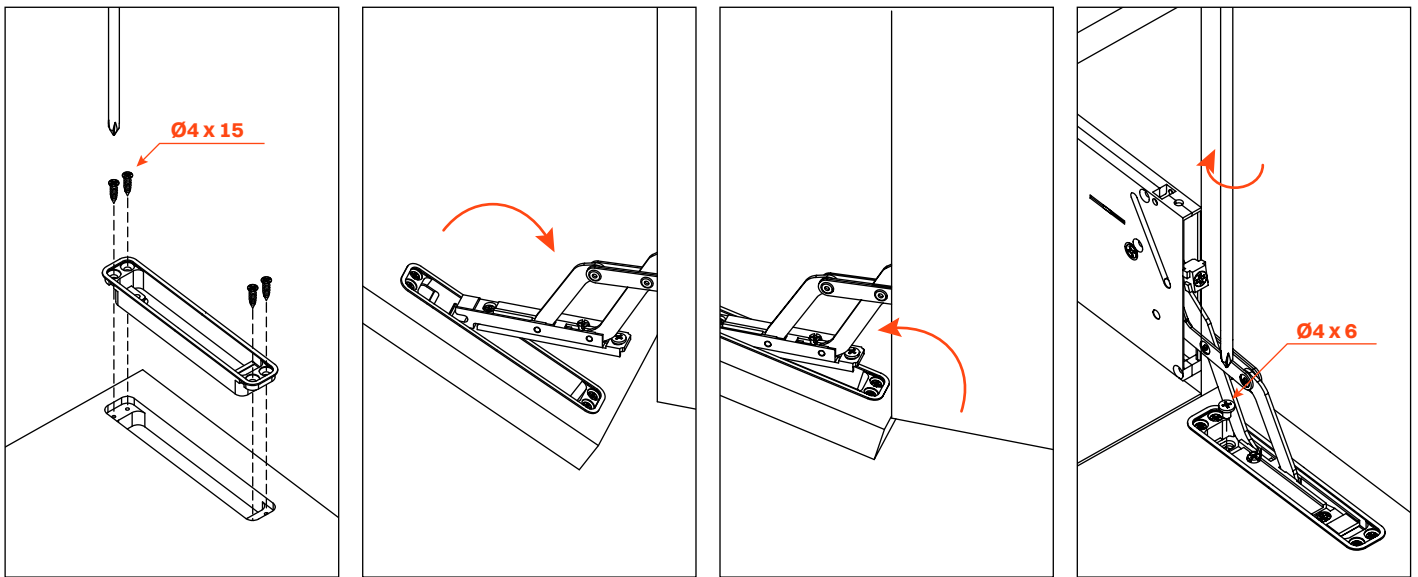

Removal of the safety stop

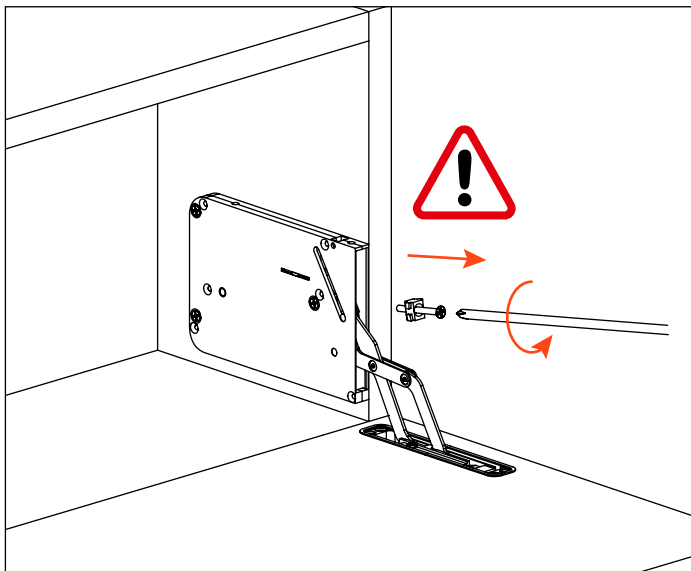

Door fixing bracket cover fastening

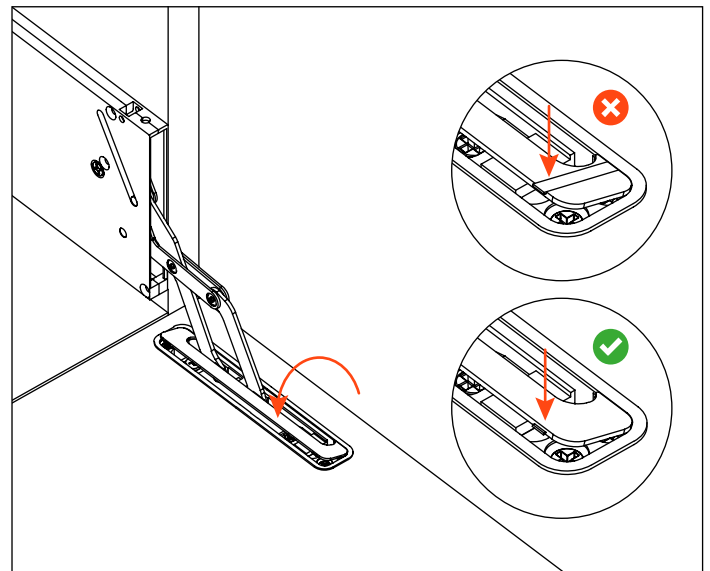

External cover assembly

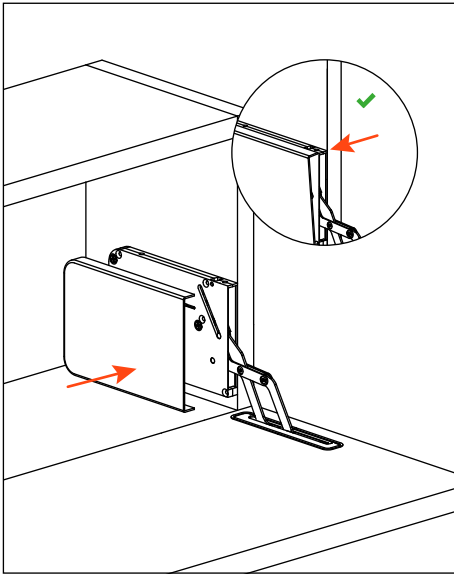

Counter side panel assembly

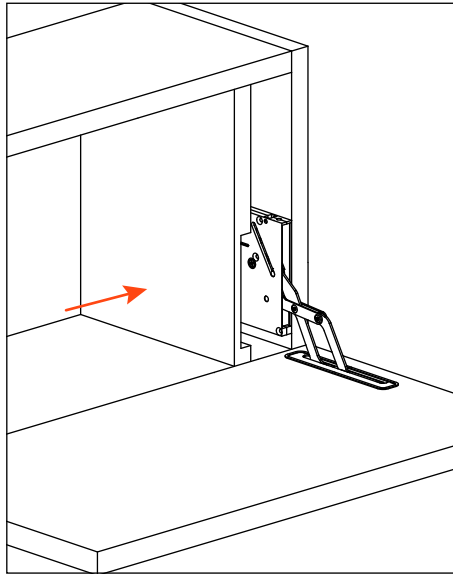

Flush cover assembly

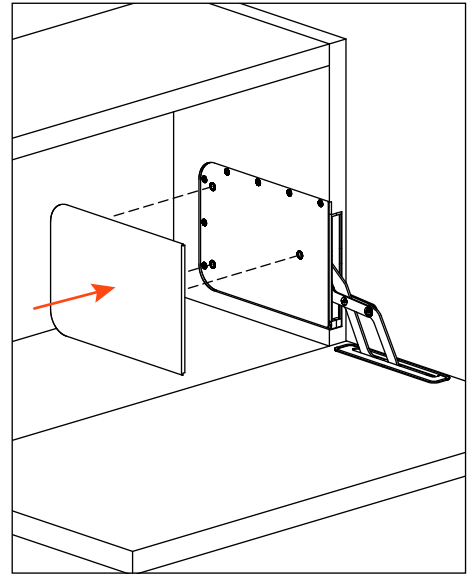

Opening strength adjustment

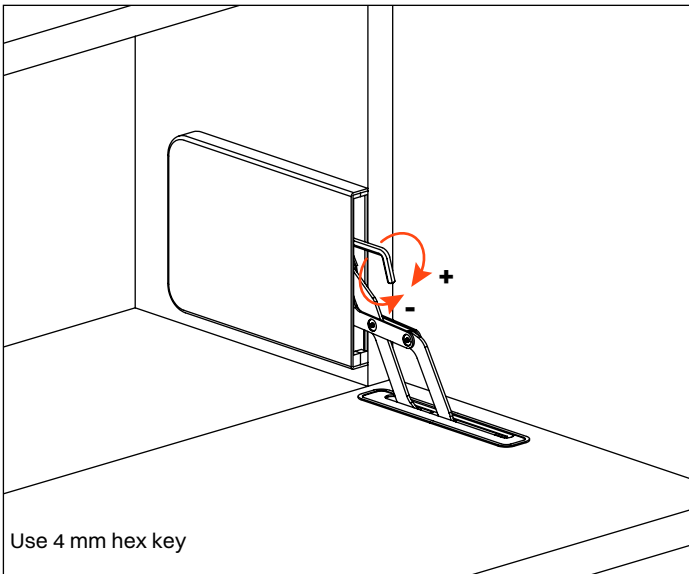

Height adjustment

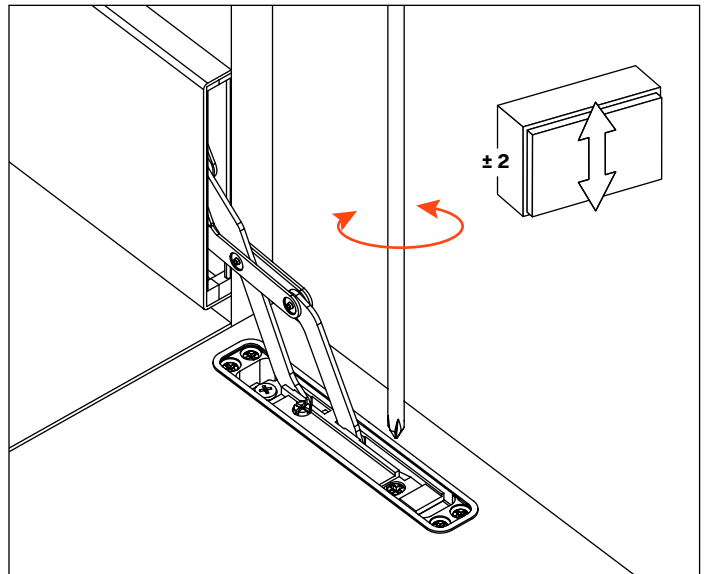

Sideways adjustment

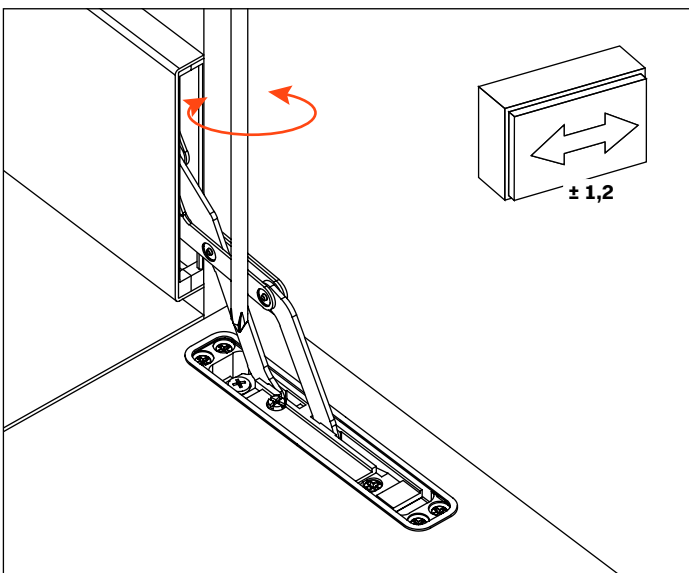

Depth adjustment

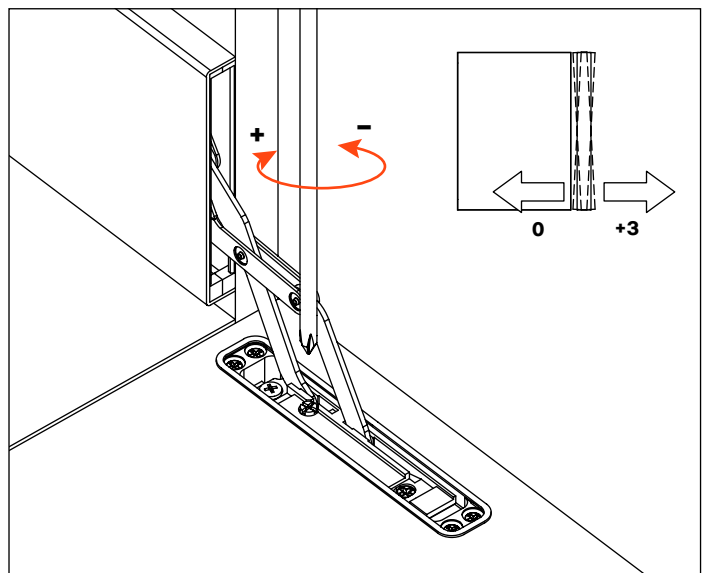

Tilt Down

System for flap doors with downward opening

Charts to determine the spring strengths according to the door weight and height.

Strength 2

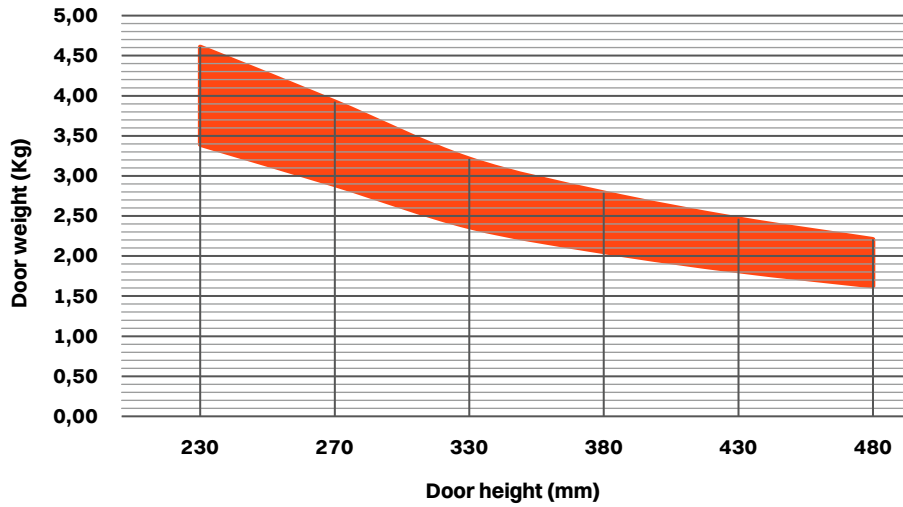

Strength 3

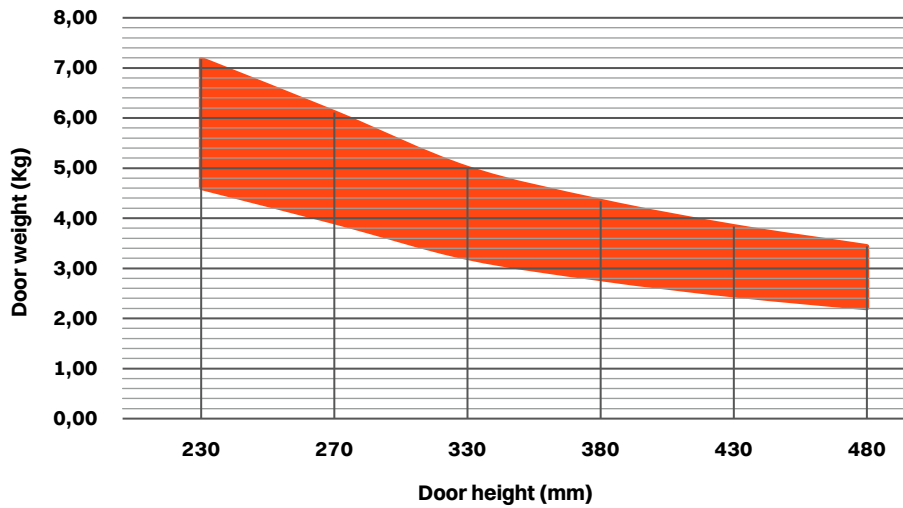

Strength 4

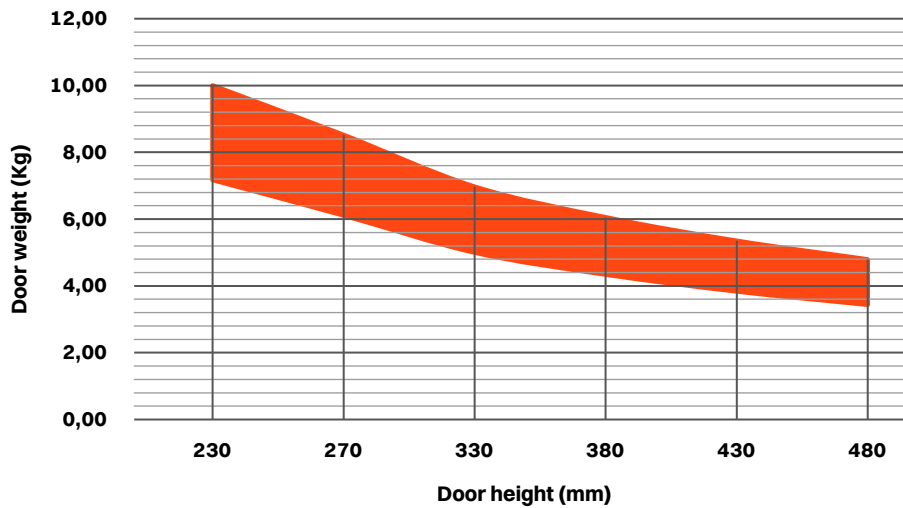

Strength 5

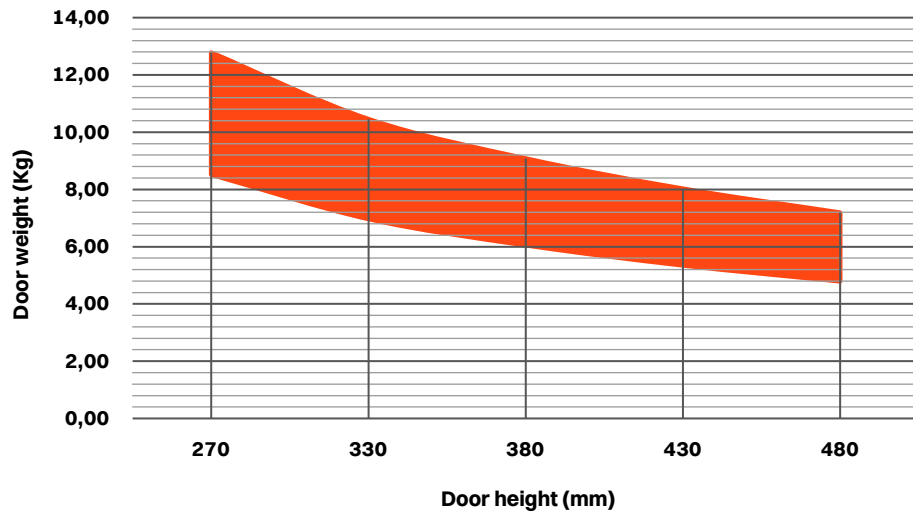

Strength 6

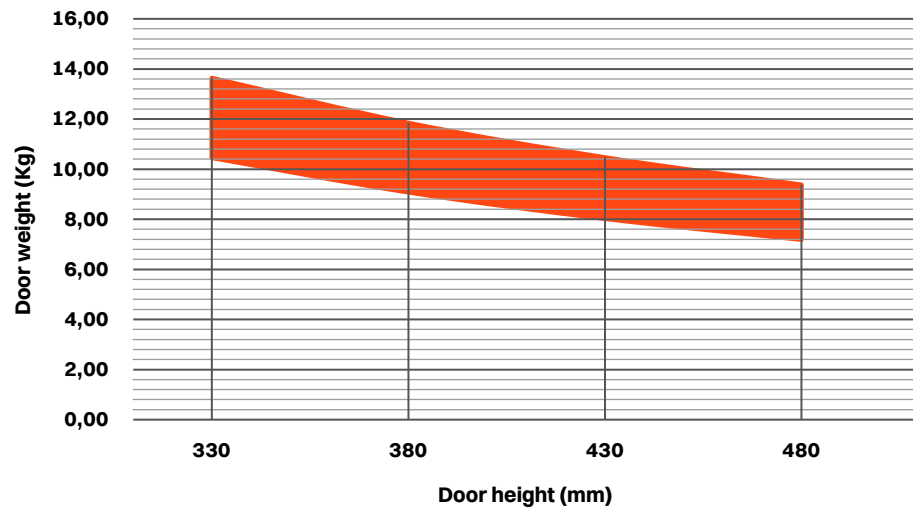



THE HOUSE THAT PINTEREST BUILT DIANE KEATON R

ARTISTS' HOUSES IN LONDON 1764-1914 GILLIAN WALKLEY
AR IN 176 GILE

VISIONARY ARCHITECTURE OF THE 20TH CENTURY AMANDA LANGSTON
THAMES AND HUDSON

GRAPHIC DESIGN REFERENCED Gernot Pölschl and Vito
nouport

Ed Laszlo Taschen
INTERIORS NOW!
2 TASCHEN

EDECOR SO CHIC
rhipacchi

Franca Trevisan Louisa
INSPIRATIONAL SPACES: TEXTURES AND SURFACES



Tilt
Packing and finishes

System	Part number	Packing	Pallet
	System for doors from 18 mm to 30 mm	<p>BOX 1 system for right side • 1 system for left side • Fixing screws included •</p> <p>CARTON 8 boxes</p>	192 boxes
	Nickel-plated finish		
	Strength 1 - FTAXFSS1SN9		
	Strength 2 - FTAXFSS2SN9		
	Strength 3 - FTAXFSS3SN9		
	Strength 4 - FTAXFSS4SN9		
	Titanium finish		
	Strength 1 - FTAXFSS1SN6		
	Strength 2 - FTAXFSS2SN6		
	Strength 3 - FTAXFSS3SN6		
	Strength 4 - FTAXFSS4SN6		

Kit for flush recessed assembly	Part number		Packing	Pallet
	STWX78A1XXXXF Signal White RAL 9003	STWX78ASXXXXF Silk Grey RAL 7044	<p>BOX 2 plates • 2 system covers • 2 door fixing bracket covers • Fixing screws included</p> <p>CARTON 8 boxes</p>	192 boxes
	STWX78ALXXXXF Desert Taupe	STWX78AMXXXXF Dusty Grey RAL 7037		
	STWX78A0XXXXF Metal Black	STWX78AZXXXXF Traffic Black RAL 9017		

Kit for external assembly	Part number		Packing
	STEX78A1XXXXF Signal White RAL 9003	STEX78ASXXXXF Silk Grey RAL 7044	<p>BOX 2 system covers • 2 door fixing bracket covers</p> <p>CARTON 8 boxes</p>
	STEX78ALXXXXF Desert Taupe	STEX78AMXXXXF Dusty Grey RAL 7037	
	STEX78A0XXXXF Metal Black	STEX78AZXXXXF Traffic Black RAL 9017	

Tilt Down Packing

System	Part number		Packing	Pallet
	System for doors from 18 mm to 22 mm	System for doors from 22 mm to 30 mm	<p>BOX 1 system for right side • 1 system for left side • Fixing screws included</p> <p>CARTON 8 boxes</p>	192 boxes
	Nickel-plated finish	Nickel-plated finish		
	Strength 2 - FTBXFSS2SN9	Strength 2 - FTBXFBS2SN9		
	Strength 3 - FTBXFSS3SN9	Strength 3 - FTBXFBS3SN9		
	Strength 4 - FTBXFSS4SN9	Strength 4 - FTBXFBS4SN9		
	Strength 5 - FTBXFSS5SN9	Strength 5 - FTBXFBS5SN9		
	Strength 6 - FTBXFSS6SN9	Strength 6 - FTBXFBS6SN9		
	Titanium finish	Titanium finish		
	Strength 2 - FTBXFSS2SN6	Strength 2 - FTBXFBS2SN6		
	Strength 3 - FTBXFSS3SN6	Strength 3 - FTBXFBS3SN6		
	Strength 4 - FTBXFSS4SN6	Strength 4 - FTBXFBS4SN6		
	Strength 5 - FTBXFSS5SN6	Strength 5 - FTBXFBS5SN6		
Strength 6 - FTBXFSS6SN6	Strength 6 - FTBXFBS6SN6			

Kit for flush recessed assembly	Part number		Packing	Pallet
	STWX78A1XXXXF Signal White RAL 9003	STWX78ASXXXXF Silk Grey RAL 7044	<p>BOX 2 plates • 2 system covers • 2 door fixing bracket covers • Fixing screws included</p> <p>CARTON 8 boxes</p>	192 boxes
	STWX78ALXXXXF Desert Taupe	STWX78AMXXXXF Dusty Grey RAL 7037		
	STWX78A0XXXXF Metal Black	STWX78AZXXXXF Traffic Black RAL 9017		

Kit for external assembly	Part number		Packing
	STEX78A1XXXXF Signal White RAL 9003	STEX78ASXXXXF Silk Grey RAL 7044	<p>BOX 2 system covers • 2 door fixing bracket covers</p> <p>CARTON 8 boxes</p>
	STEX78ALXXXXF Desert Taupe	STEX78AMXXXXF Dusty Grey RAL 7037	
	STEX78A0XXXXF Metal Black	STEX78AZXXXXF Traffic Black RAL 9017	

Tilt Up - Down

Finishes

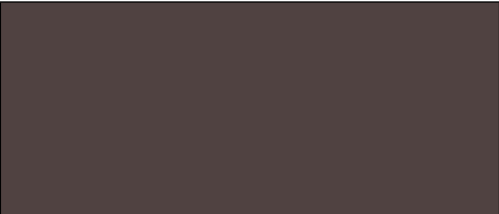
System finishes	
	9 - Nickel-plated
	6 - Titanium

Cover finishes	Kit for flush recessed assembly	Kit for external assembly
	STWX78A1XXXXF Signal White - RAL 9003	STEX78A1XXXXF Signal White - RAL 9003
	STWX78ASXXXXF Silk Grey - RAL 7044	STEX78ASXXXXF Silk Grey - RAL 7044
	STWX78ALXXXXF Desert Taupe	STEX78ALXXXXF Desert Taupe
	STWX78AMXXXXF Dusty Grey - RAL 7037	STEX78AMXXXXF Dusty Grey - RAL 7037
	STWX78A0XXXXF Metal Black	STEX78A0XXXXF Metal Black
	STWX78AZXXXXF Traffic Black - RAL 9017	STEX78AZXXXXF Traffic Black - RAL 9017

HEADQUARTERS AND PRODUCTION UNITS

ARTURO SALICE S.p.A.

HEAD OFFICE

VIA PROVINCIALE NOVEDRATESE, 10
22060 NOVEDRATE (COMO) ITALIA
TEL. 031 790424 - FAX 031 791508
info.salice@salice.com
www.salice.com

ARTURO SALICE S.p.A.

VIA ARISTIDE MERLONI, 11
61036 COLLI AL METAURO (PU) ITALIA
TEL. 0721 899800
FAX 0721 897980
info.salice@salice.com
www.salice.com

BORTOLUZZI SISTEMI S.p.A.

VIA CADUTI 14 SETTEMBRE 1944, 45
32100 BELLUNO (BL) ITALIA
TEL. 0437 930866
FAX 0437 931442
info@bortoluzzi.com
www.salice.com

NUOVA ATIM S.r.l.

VIA IV NOVEMBRE, 52
20019 SETTIMO MILANESE (MI) ITALIA
TEL. 02 33503203
FAX 02 33516514
info@atimspa.com
www.atimspa.com

VILLES S.r.l.

VIA CASTOLDI, 6/8
20090 TREZZANO SUL NAVIGLIO (MI) ITALIA
TEL. 02 4452083
FAX 02 4452838
info@villes2000.com
www.villes2000.com

BRANCHES

DEUTSCHE SALICE GMBH

RUDOLF DIESEL STR. 10
74382 NECKARWESTHEIM
TEL. 07133 9807-0
FAX. 07133 9807-16
info.salice@deutschesalice.de
www.salice.com

DEUTSCHE SALICE GMBH

VERKAUFSBÜRO NORD
RINGSTRASSE 36/A30 CENTER
32584 LÖHNE
TEL. 05731 15608-0
FAX. 05731 15608-10
vknord@deutschesalice.de
www.salice.com

SALICE UK LTD.

KINGFISHER WAY
HINCHINGBROOKE BUSINESS PARK
HUNTINGDON CAMBS PE 29 6FN
TEL. 01480 413831
FAX. 01480 451489
info.salice@saliceuk.co.uk
www.salice.com

SALICE FRANCE S.A.R.L.

285 RUE DE GOA ZAC LES 3 MOULINS
06600 ANTIBES
TEL. 0493 330069
FAX. 0493 330141
info.salice@salicefrance.com
www.salice.com

SALICE ESPAÑA, S.L.U.

C/ AIGUAFREDA 4, P.I. AMETLLA PARK
08480 L'AMETLLA DEL VALLÈS (BARCELONA)
TEL. 0034 938 46 88 61
info.salice@saliceespana.es
www.salice.com

SALICE PORTUGAL UNIP. LDA

SHOWROOM:
TV SÁ E MELO 161 FA
4470-116 MAIA - PORTO
TEL: 00351 224 154 221
Info@saliceportugal.pt
www.salice.com

ARMAZÉM:
VIA ROTA DOS MÓVEIS I 399
4585-325 GANDRA

SALICE CHINA (SHANGHAI) CO. LTD.

RM 602, 6/F, TOWER 1,
3688 YINGGANG DONG ROAD
QINGPU DISTRICT
201703 SHANGHAI, CHINA
TEL. 021 3988-9880
info.salice@salicechina.com
www.salicechina.com

SALICE INDIA PVT. LTD.

1001 & 1002, 10TH FLOOR,
CENTRUM, PLOT NO. C-3,
OPP. WAGLE PRABHAG SAMITI OFFICE,
MIDC AREA, WAGLE INDUSTRIAL ESTATE,
THANE - 400604, MAHARASHTRA
TEL. 022 20812050
info@saliceindia.com
www.salice.com

SALICE CANADA INC.

3500 RIDGEWAY DRIVE,
UNIT#1
MISSISSAUGA, ONTARIO, L5L 0B4
TEL. 905 820 8787
FAX. 905 820 7226
info.salice@salicecanada.com
www.salicecanada.com

SALICE AMERICA INC.

2123 CROWN CENTRE DRIVE
CHARLOTTE NC. 28227
TEL. 704 841 7810
FAX. 704 841 7808
info.salice@saliceamerica.com
www.saliceamerica.com

ARTURO SALICE S.p.A.

HEAD OFFICE

VIA PROVINCIALE NOVEDRATESE, 10
22060 NOVEDRATE (COMO) ITALIA
TEL. 031 790424 - FAX 031 791508

info.salice@salice.com
www.salice.com

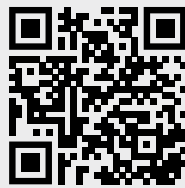

Digital contents