

A close-up photograph of a white, curved hinge mounted on a wooden flap door. The door is made of a light-colored wood with a visible grain. The hinge is positioned at the top edge of the door, where it meets a white wall. The background is a plain, light-colored wall. The image is partially obscured by a white diagonal shape that separates it from the text on the right.

SALICE

Pacta

hinge for flap doors

ENG



Pacta

FLAWLESS OPENING, EVERY DROP.

Compactness and functionality for flap doors.

Compact design, high performance

- Compact, self-supporting hinge, designed for flap doors.
- Clean, linear design with no external support elements.
- Cover caps available in different finishes to blend harmoniously with the cabinet style.
- Matching covers available for the version with a central hinge on large-size doors.

Fast, functional installation

- Quick door fixing via longitudinal quick-mount base plates.
- Direct, three-way adjustment for precise alignment.
- Integrated decelerator that gently guides the door to the fully open position.
- Reliability certified by vertical load test according to EN 15828:2010, Level 3.
- Adjustable central hinge, ideal for wooden doors wider than 900 mm.

Versatility

- Suitable for wooden or aluminium-frame doors.
- Soft-down motion.
- Compatible with Smove or Push systems for handle-less doors.



Pacta

Compact design, high performance

Essential in form yet outstanding in performance:
Pacta is the hinge for flap doors that works without cables or pistons, delivering a clean look and advanced mechanics.

During opening, the door moves with a smooth, controlled action thanks to the integrated deceleration, until it forms a surface perfectly flush with the cabinet base.

MOVIE * ICONS CHARLES CHAPLIN TAS
MOVIE * ICONS TOM CRUISE TAS
MOVIE * ICONS SIGOURNEY WEAVER TAS
MOVIE * ICONS JOHN TRAVOLTA TAS



Pacta

Versatility in everyday spaces

Also available in a Push version, Pacta is ideal for smart, space-saving solutions in kitchens, living rooms, hotels, and children's rooms.

When open, the door can turn into a bar shelf, a small writing surface, or a functional desk — all with a single, elegant movement.

Pacta can be fitted to wooden or aluminium-profile doors.

Elegant design

A refined range of finishes makes Pacta perfect for any interior, backed by the reliability that defines premium systems.

Pacta
Hinge for wooden doors

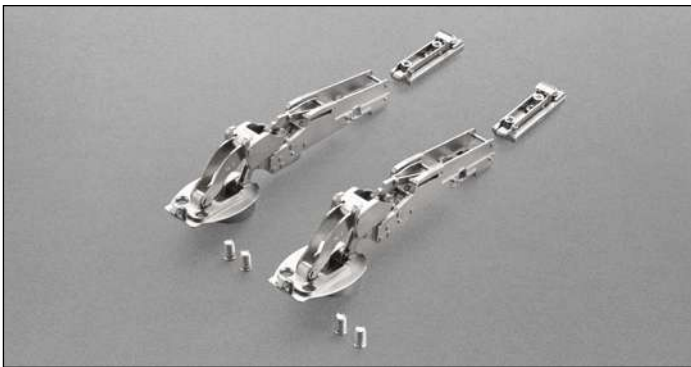

Technical information

**Hinge for flap doors with decelerated opening.
Sprung closing action.**

Fixing to the base of the cabinet with longitudinal snap-on mounting plate (BAPGR29/16).
Standard drilling of the door $\varnothing 35$.
13 mm deep cup.
90° opening.
Fixed $K = 4.5$ mm.
Also available in Push to open version for handle-less doors.

Pacta is tested and certified to level 3 of UNI EN 15828:2010

Drilling patterns

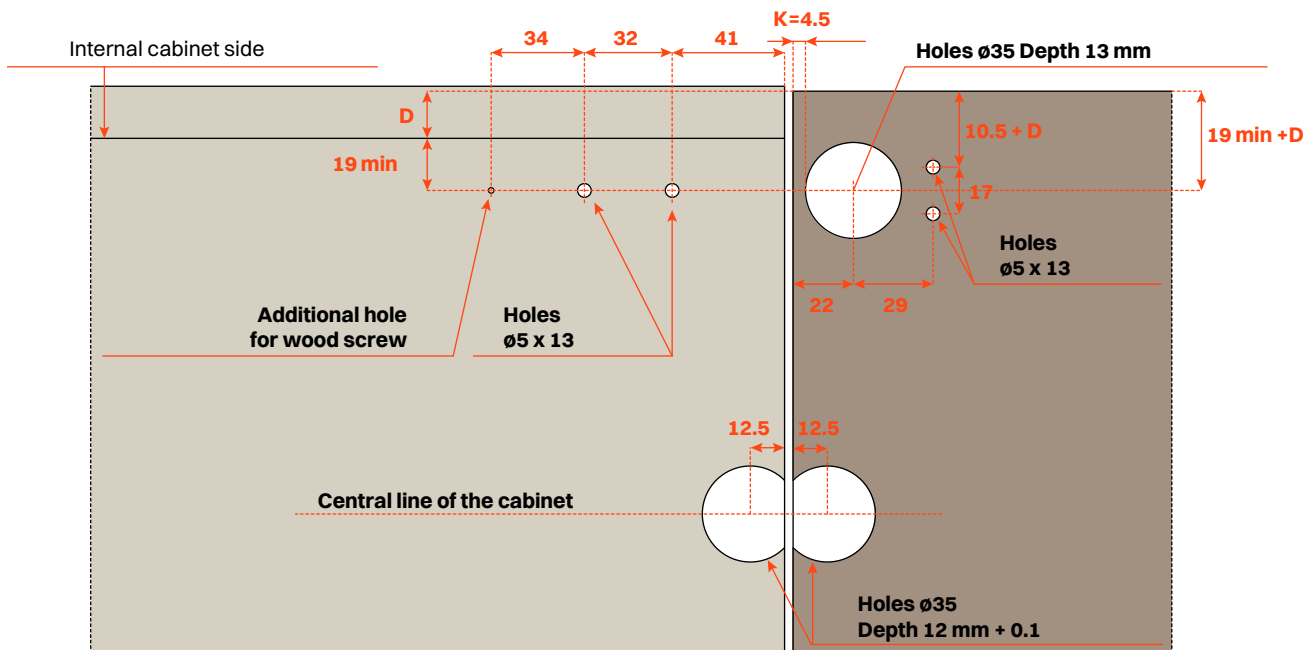
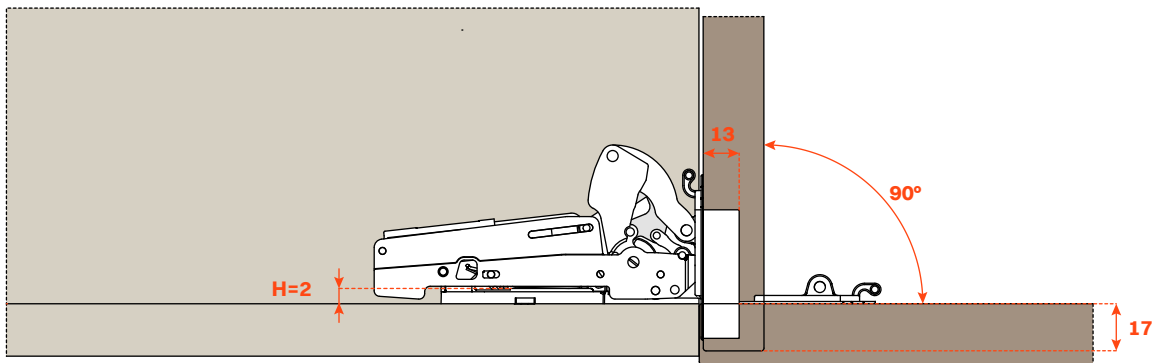

Space needed to open the door

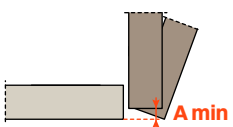

T=	16	17	18	19	20	21	22	23	24	25	26	27	28
K=4.5 A=	1.3	2.1	3	3.9	4.8	5.7	6.6	7.5	8.5	9.4	10.4	11.3	12.3

Hinge for aluminium framed doors

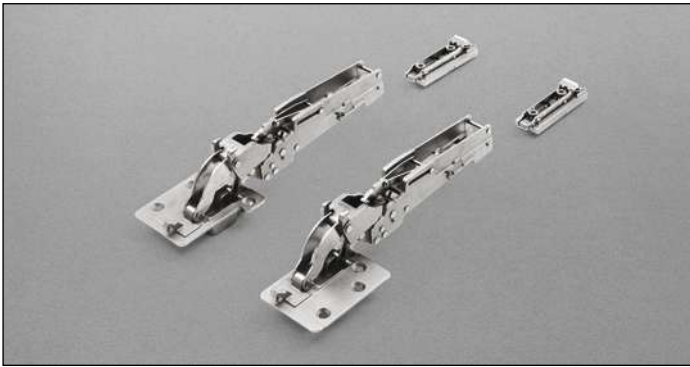

Technical information

**Hinge for flap doors with decelerated opening.
Sprung closing action.**

Fixing to the base of the cabinet with longitudinal snap-on mounting plate (BAPGR29/16).
12 mm deep cup.
90° opening.
Fixed K = 4.5 mm.
Also available in Push to open version for handle-less doors.

Drilling patterns

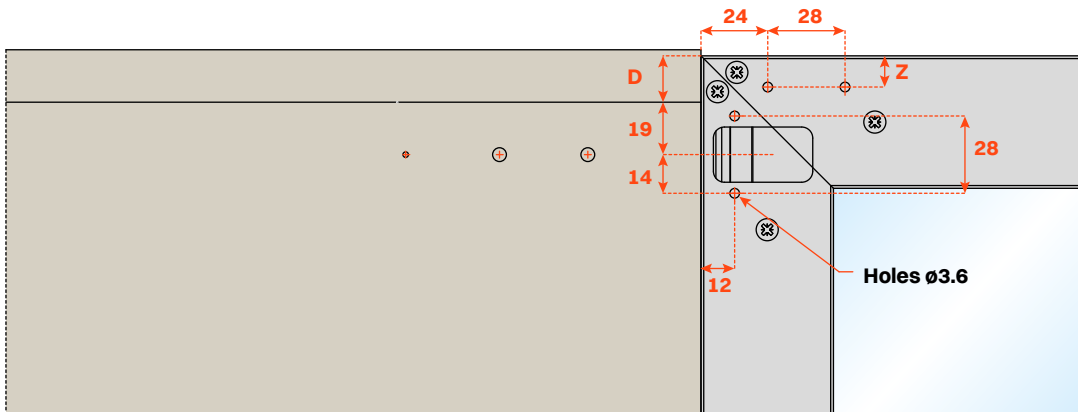
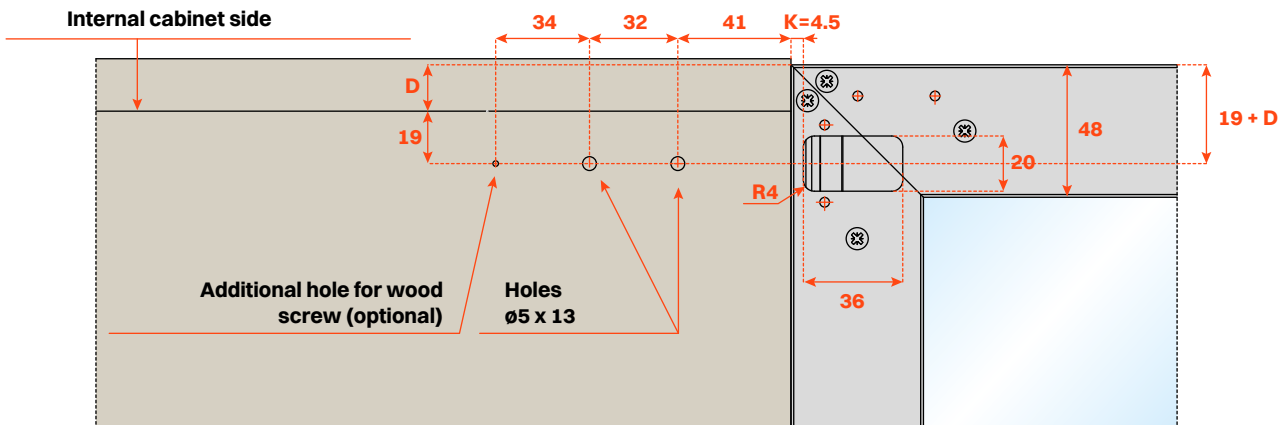
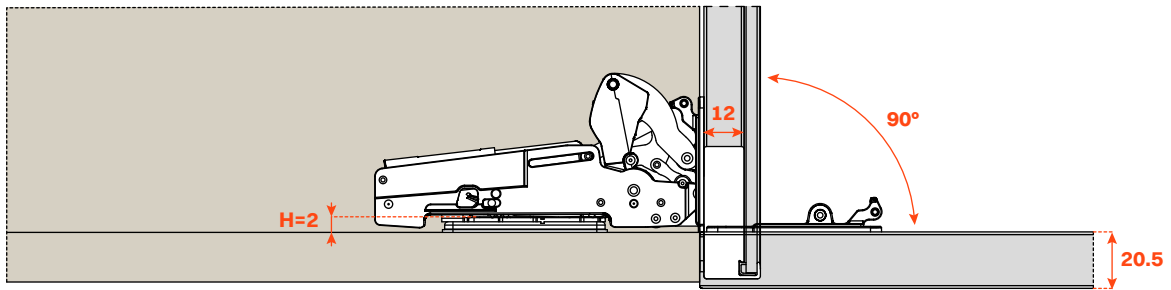

Pacta
Assembly instructions

Fixing the mounting plate to the cabinet

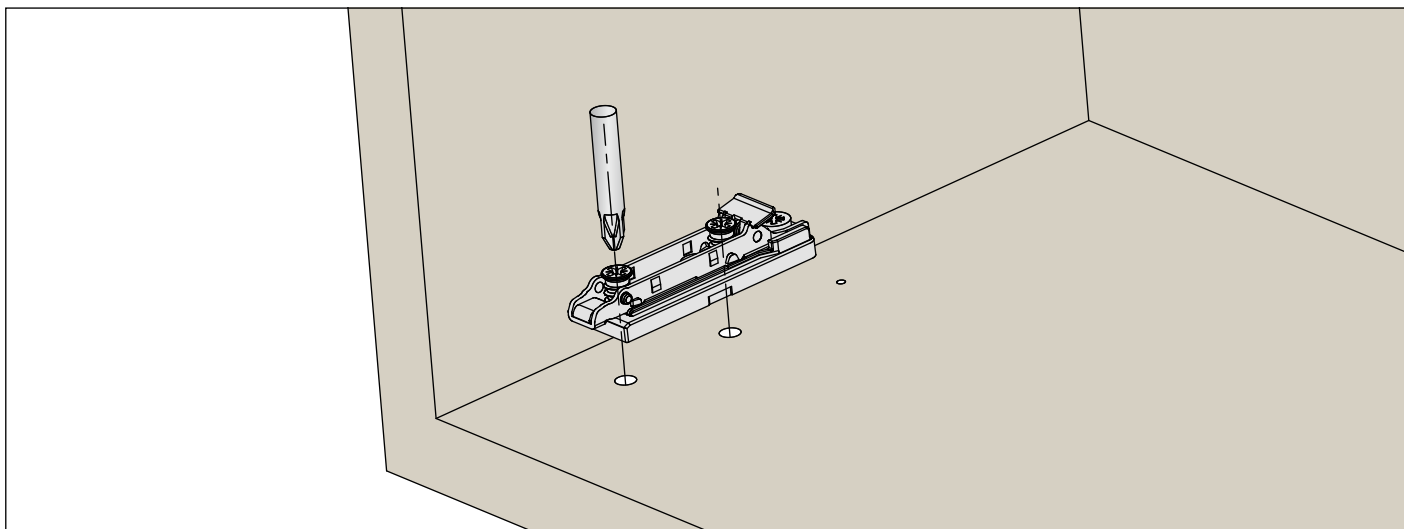

Fixing the hinge to the door

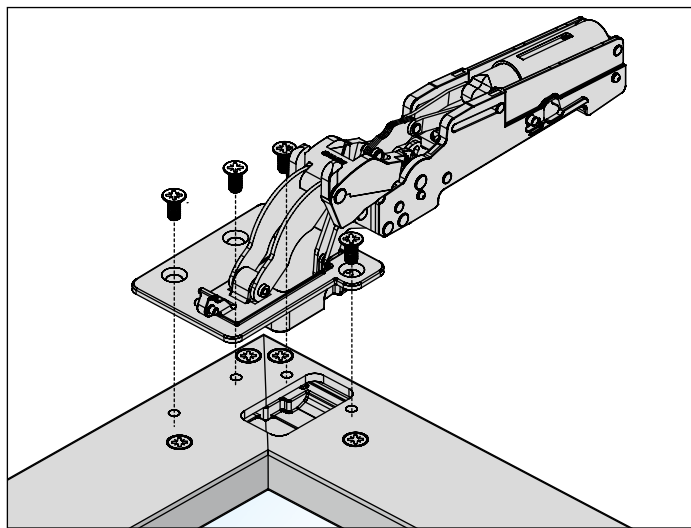
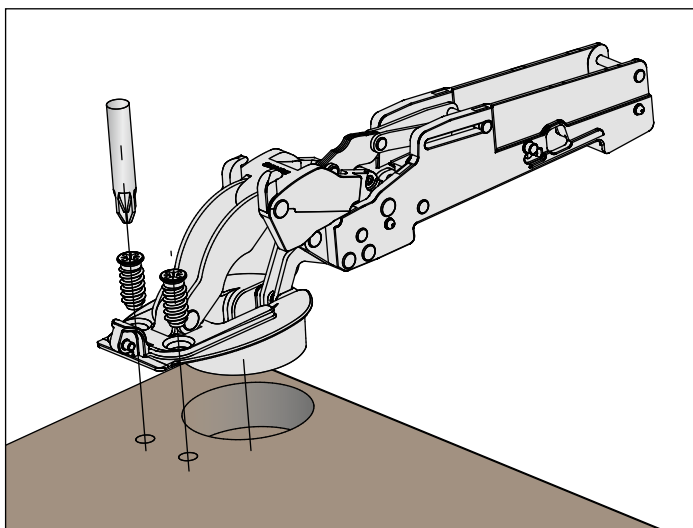

Mounting the door onto the cabinet

Clip the hinge arm onto the mounting plates. This operation is tool free.

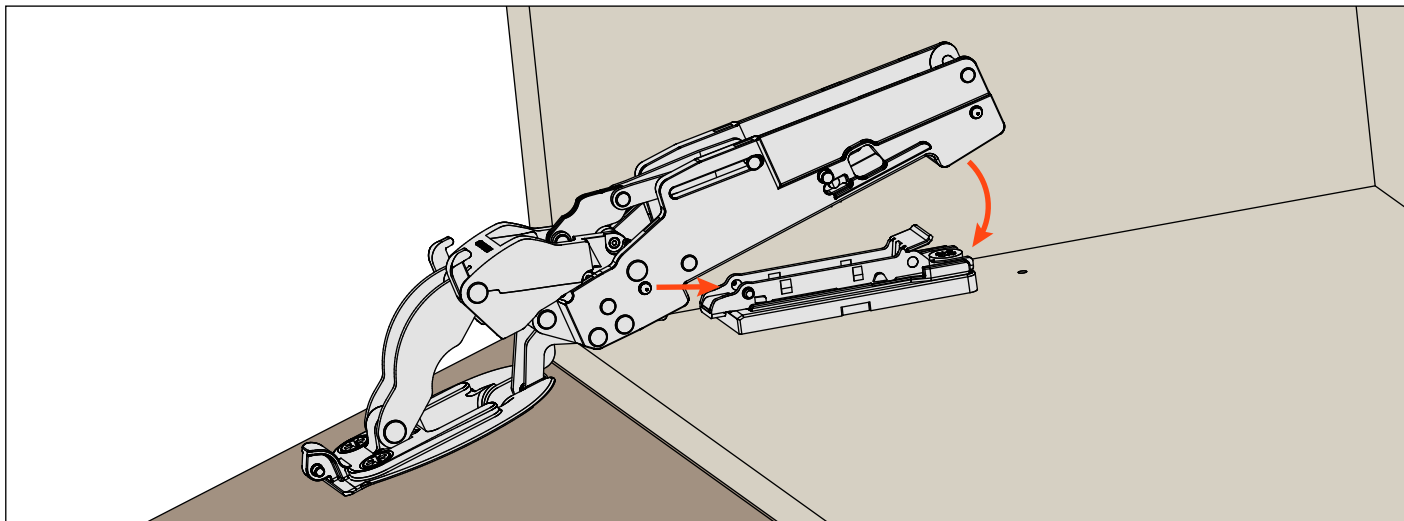

Adjustments

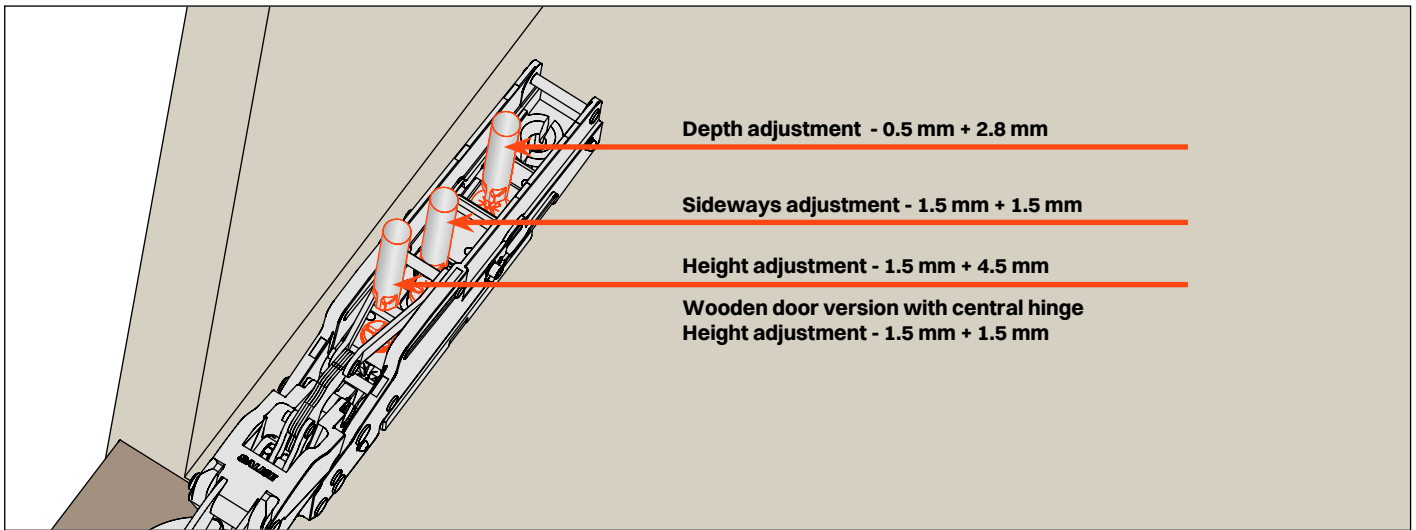

Fix the security screw

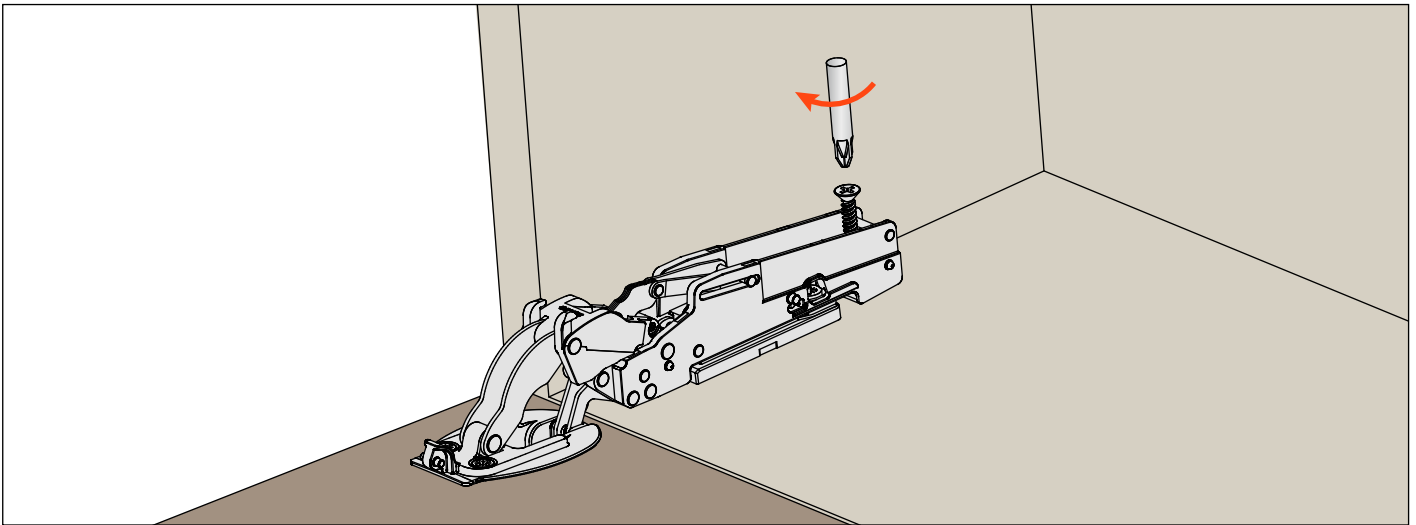

Installing the Smove

Clip the narrow end of the Smove into position. This operation is tool free.

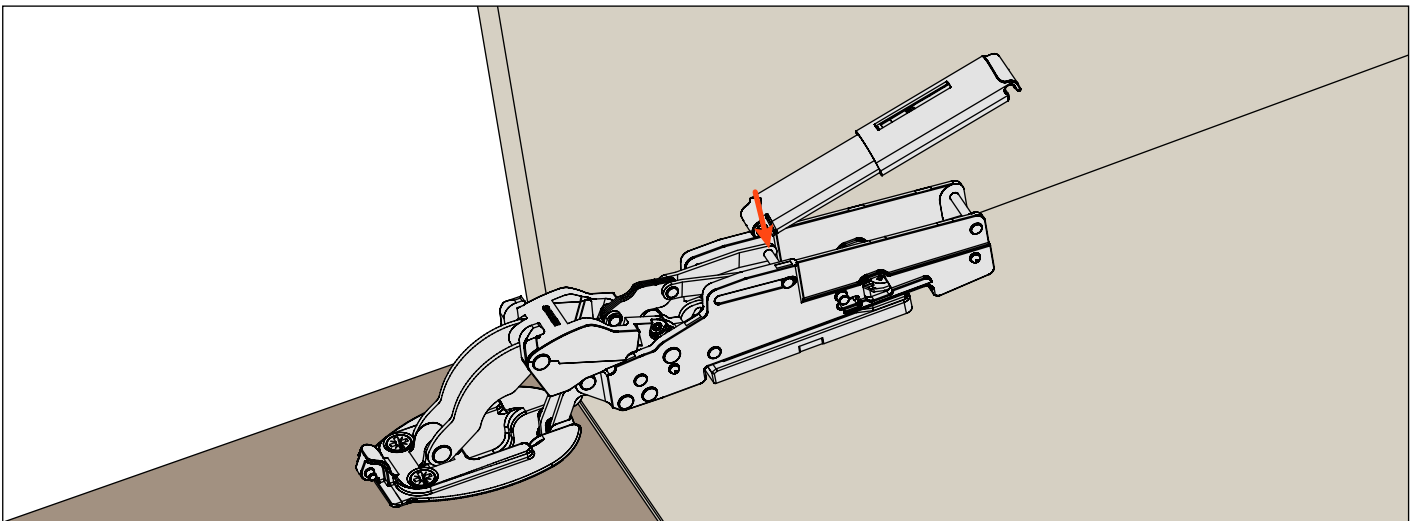

Pacta
Assembly instructions

Lift the flap slightly and clip the other end of the Smove into position. This operation is tool free.

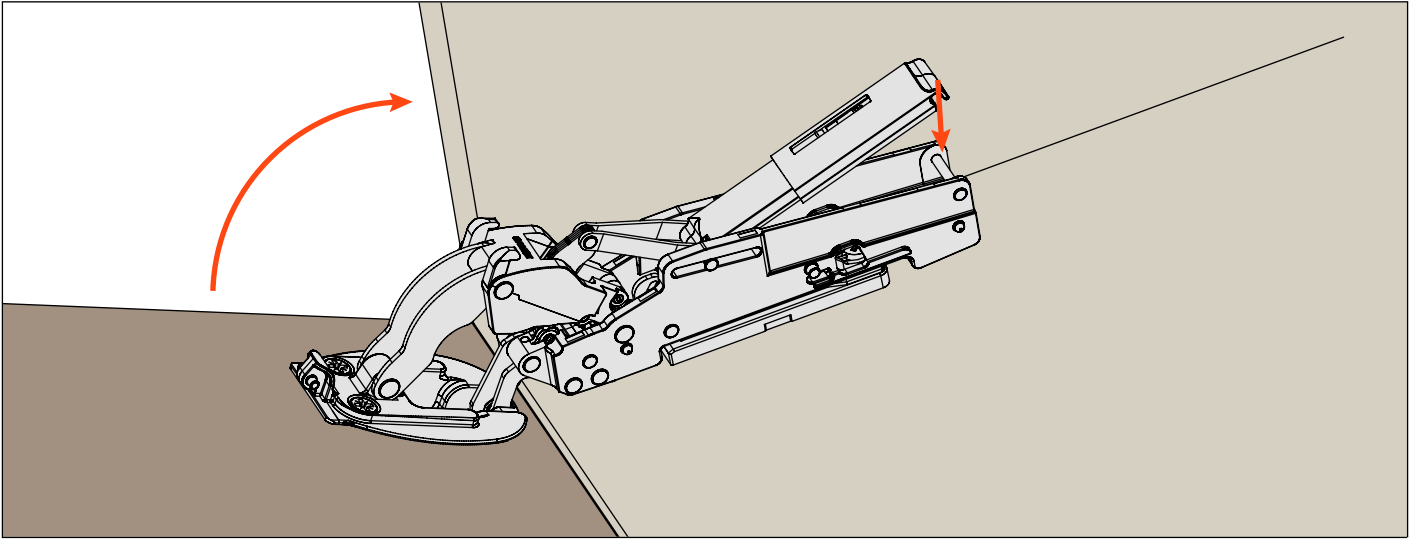

Installing the cover

Firstly install the cover on the hinge arm and then to the cup.

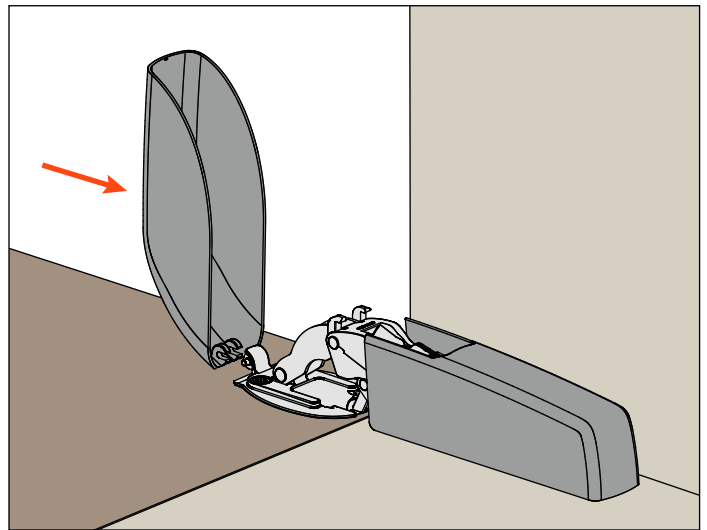
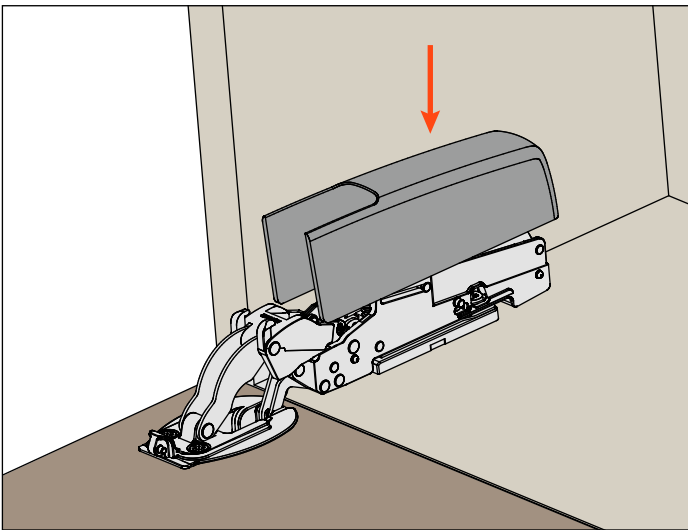

Dimensions

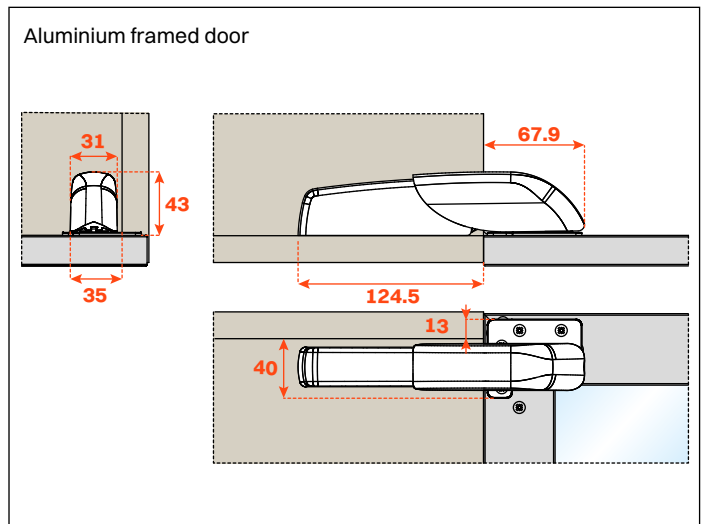
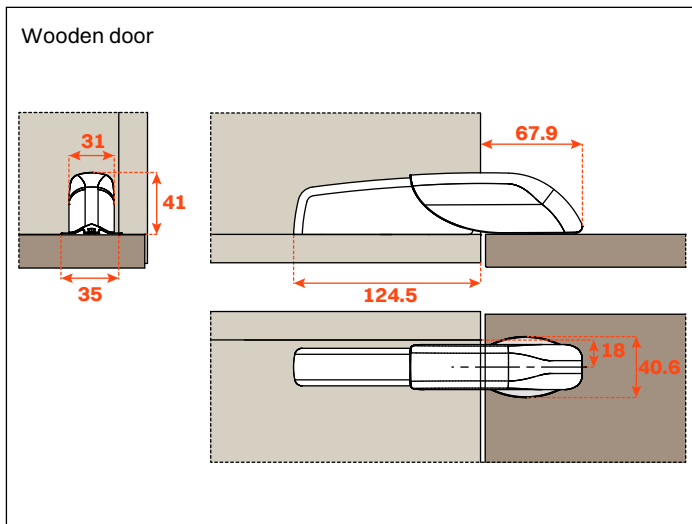

Assembly instructions for the central hinge only for wooden doors

Application of the central hinge

We suggest that you use the central hinge for cabinets over 900 mm width. Install the cover cap onto the hinge according to the drawing and then screw-fix the hinge to the cabinet.

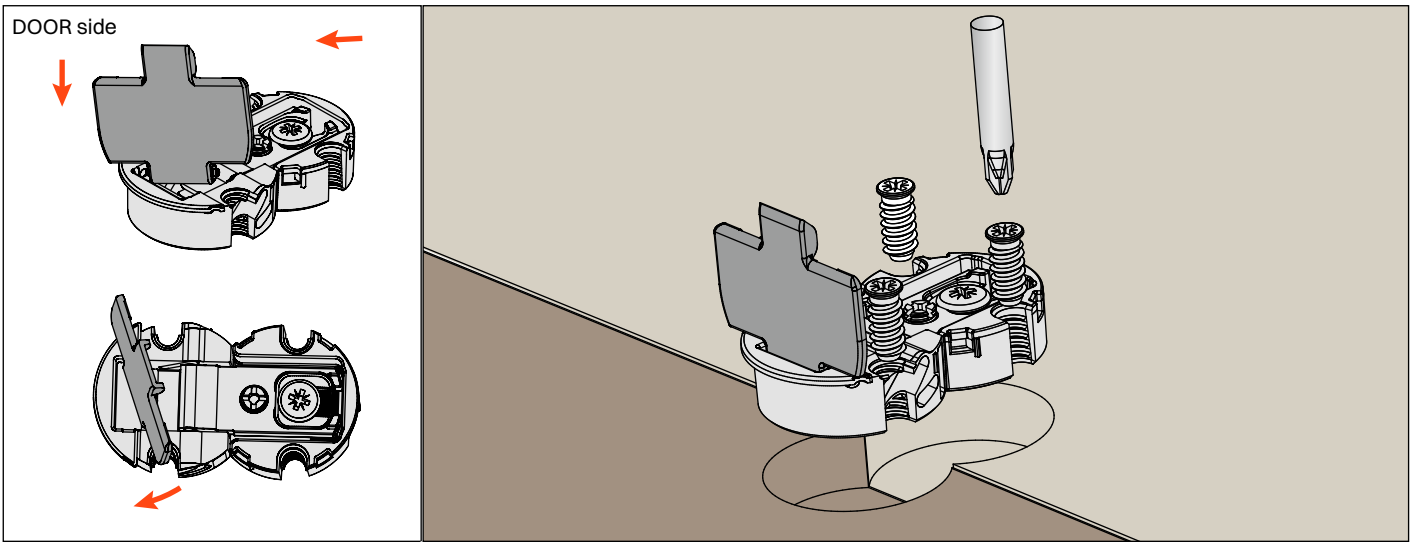

After fixing the hinge, make any adjustments required

Install the cover cap onto the hinge on the cabinet side

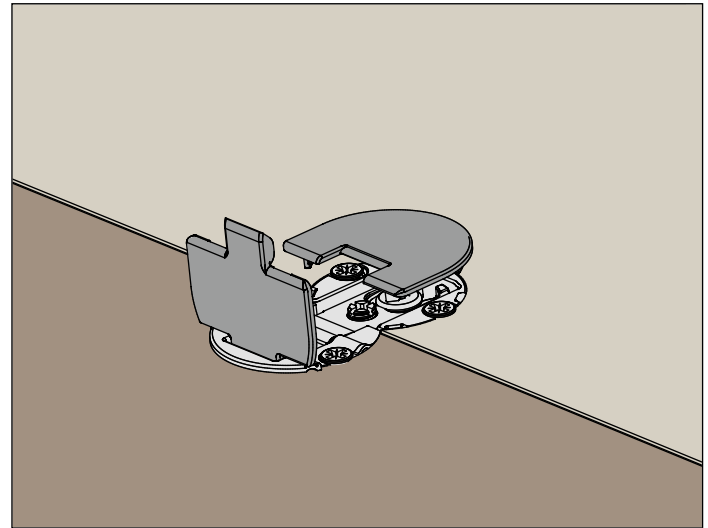
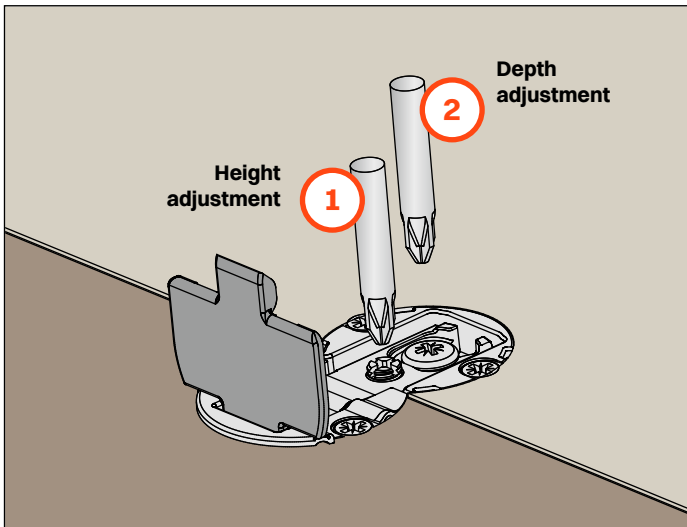

Overall view of the mounted hinges.

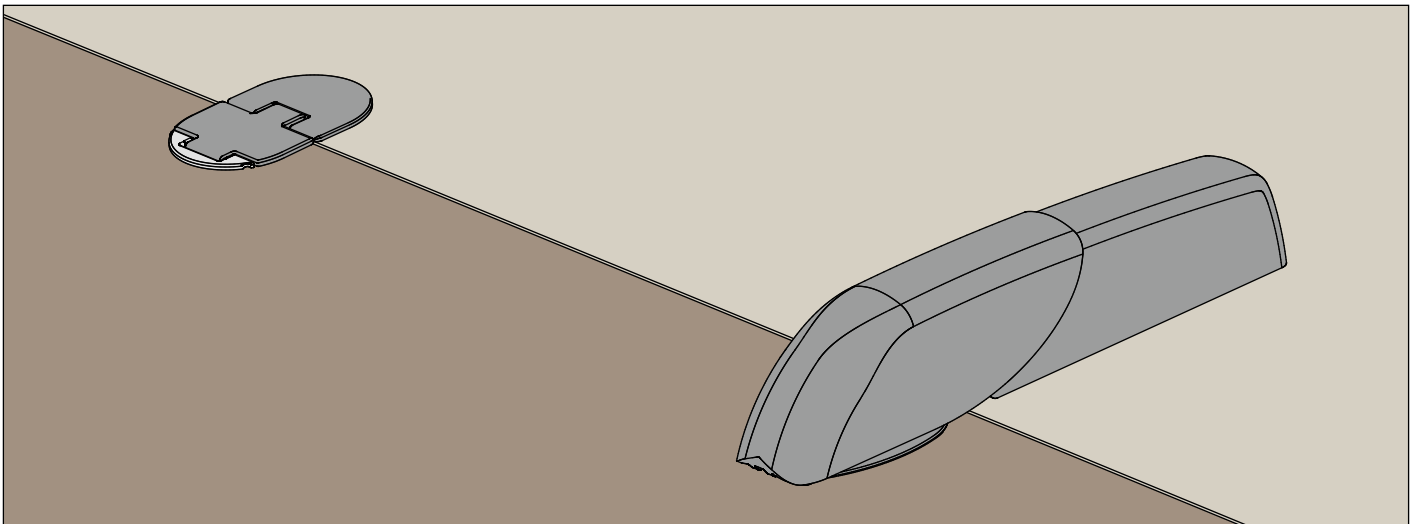

Pacta
Disassembly instructions

Removal of the cover

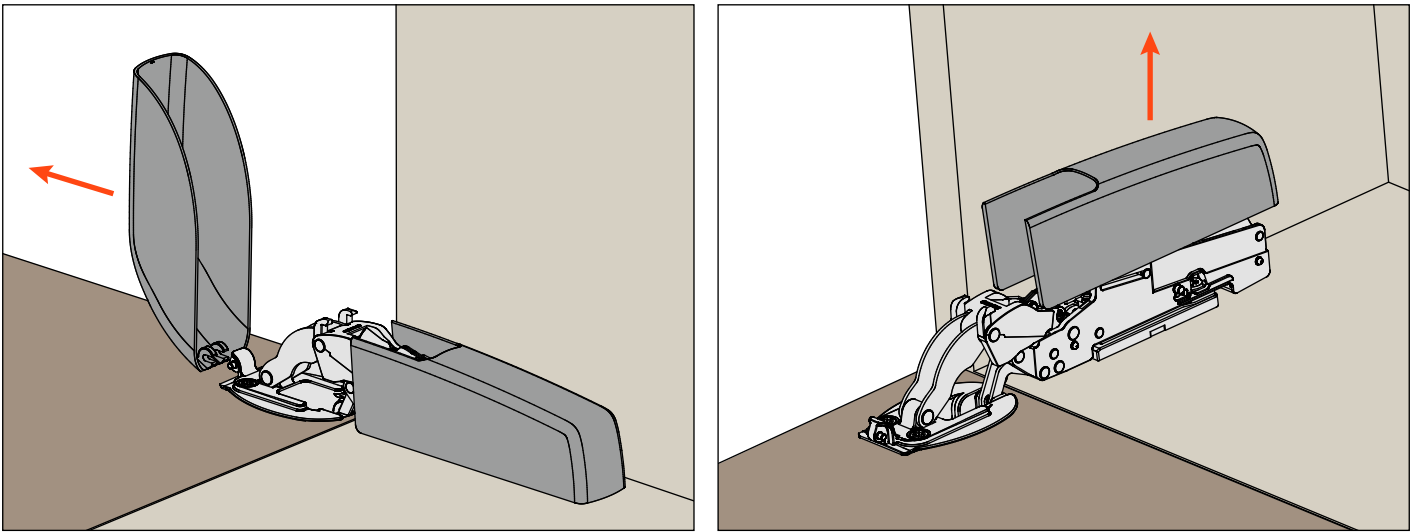

Disassembly of the Smove

Lift the flap slightly and unclip the back of the Smove using a screwdriver.

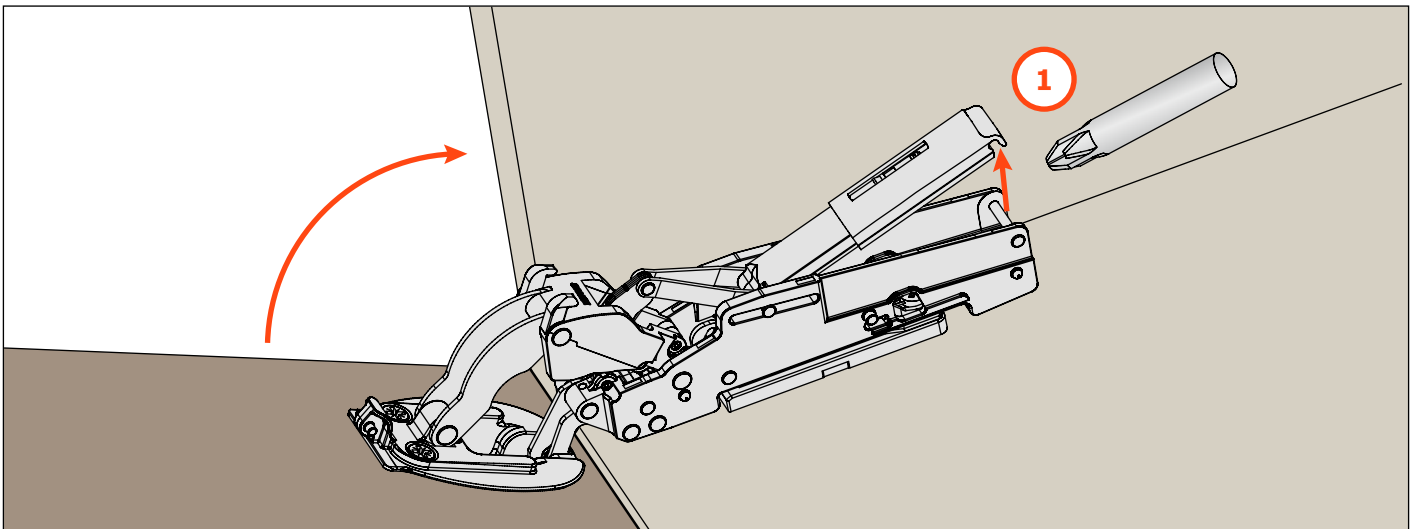

Remove the other end of the Smove.

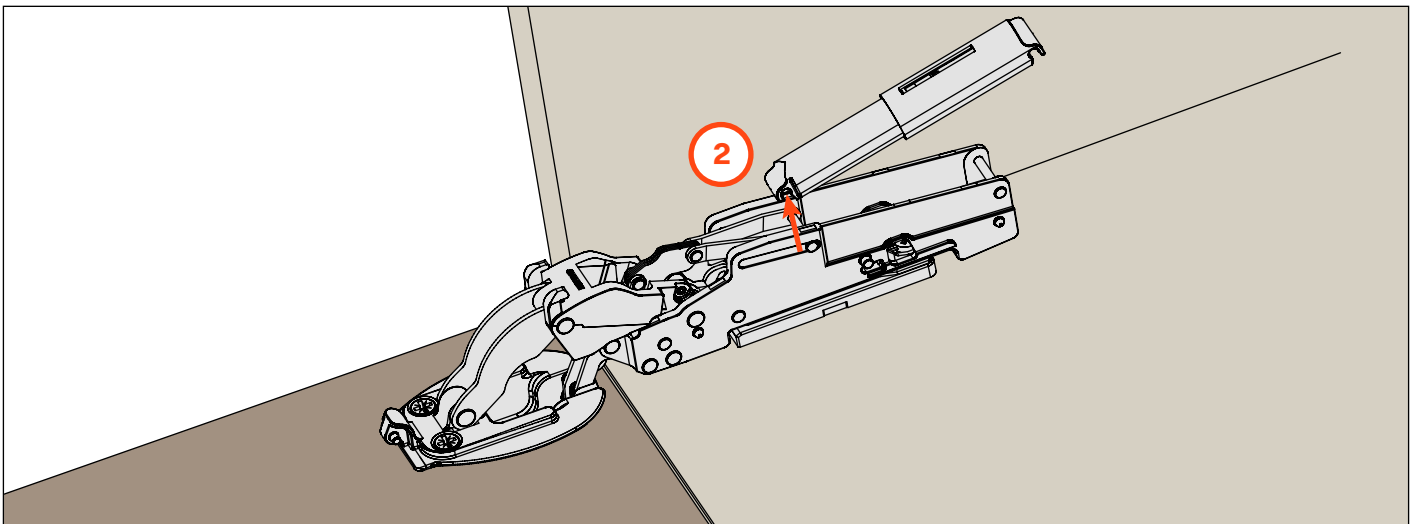

Remove the security screw

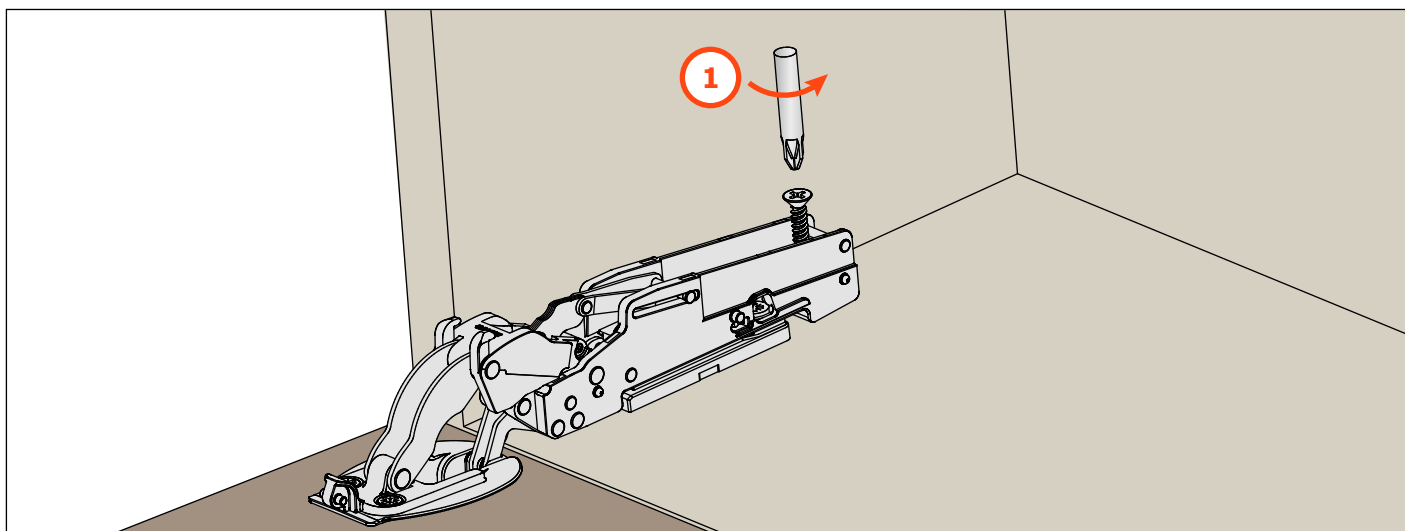

Unfasten the hinge from the mounting plate with a screwdriver

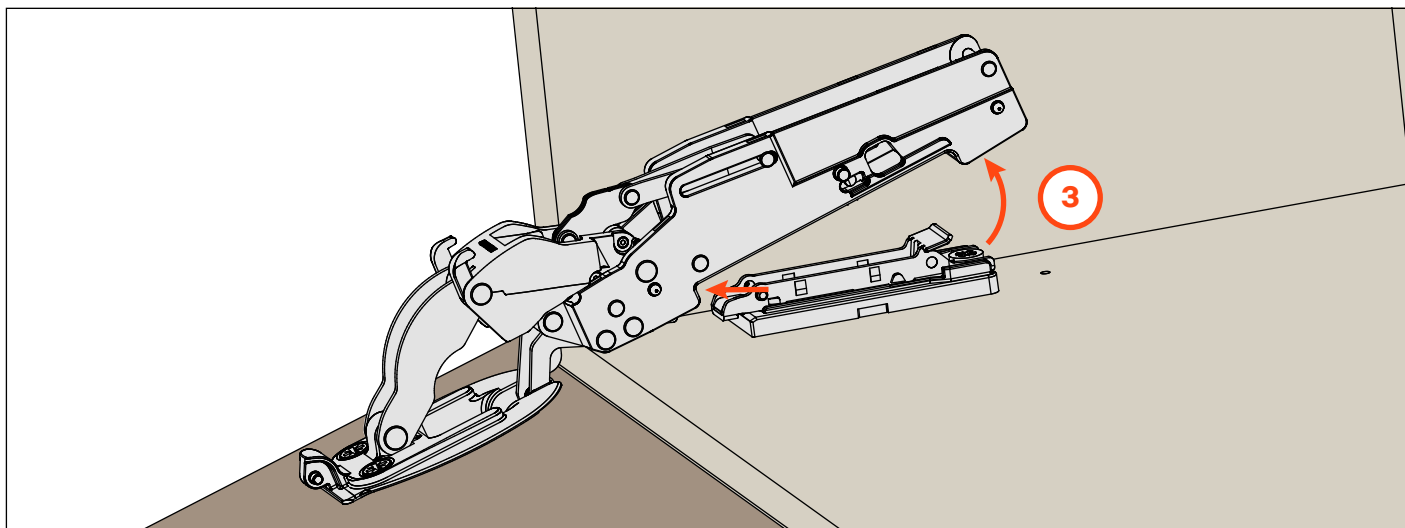
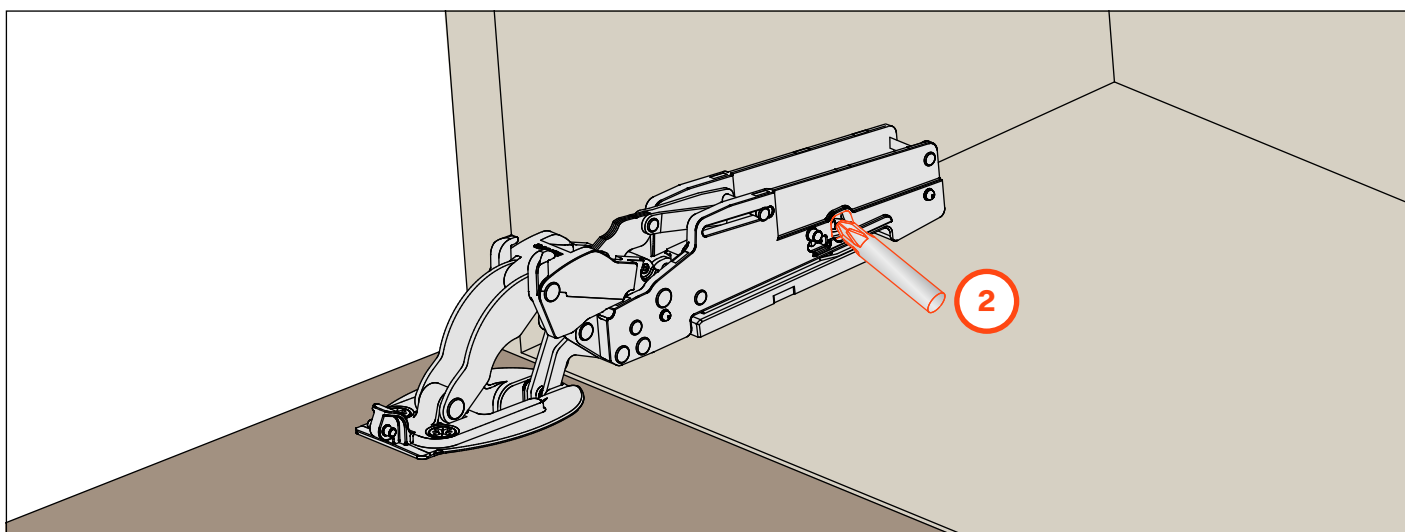

Pacta
Colours of the cover

SRX B78A1XXXNF

White

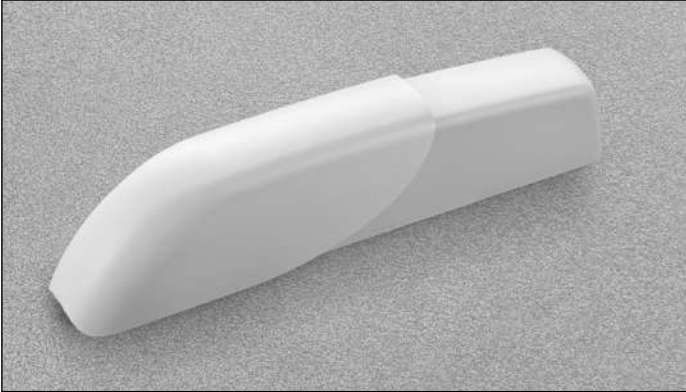

SRXB78AQXXXNF

Glossy white

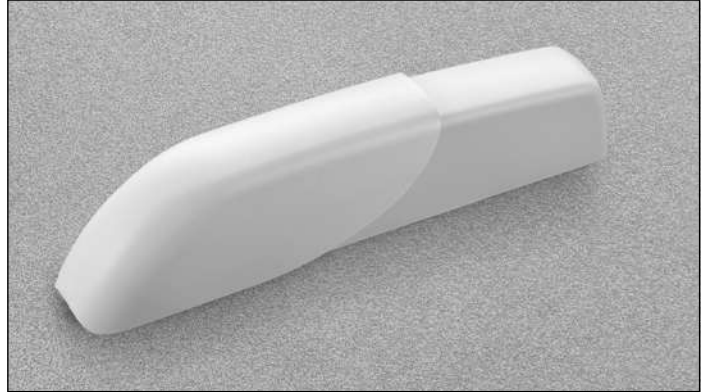

SRXB78AIXXXNF

Stainless steel



SRXB78AMXXXNF

Grey



SRXB78ACXXXNF

Champagne



SRXB78A0XXXNF

Satin metal black

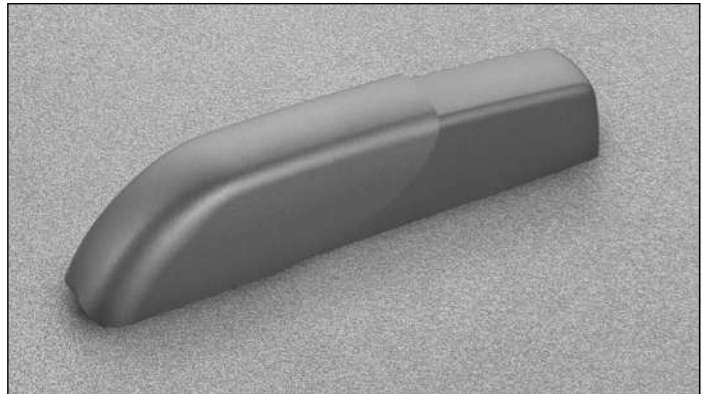

SRXB78ANXXXNF

Glossy metal black



Colours of the cover cap for the central hinge

FRCK59RXXX1

White

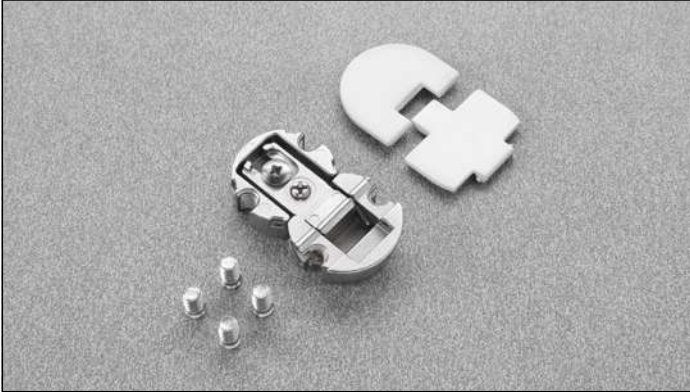

FRCK59RXXXQ

Glossy white

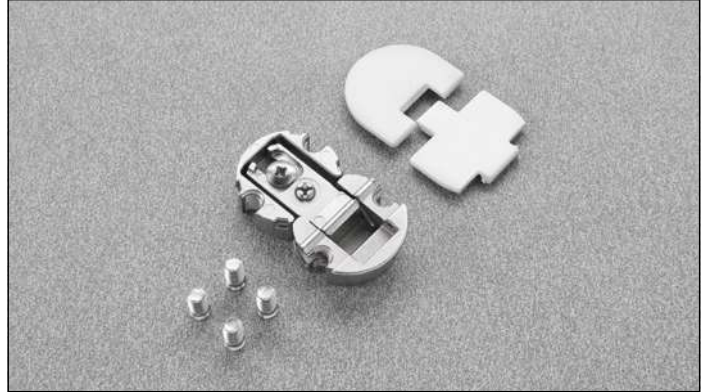

FRCK59RXXXI

Stainless steel

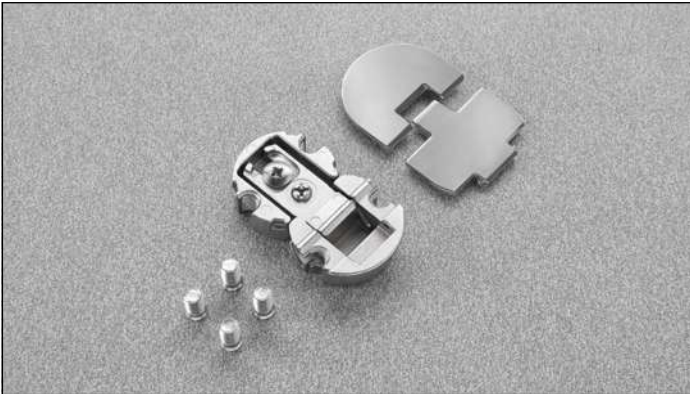

FRCK59RXXXM

Grey

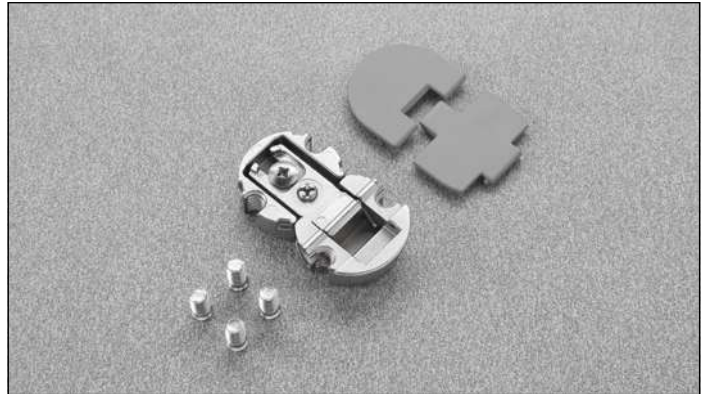

FRCK59RXXXC

Champagne



FRCK59RXXX0

Satin metal black

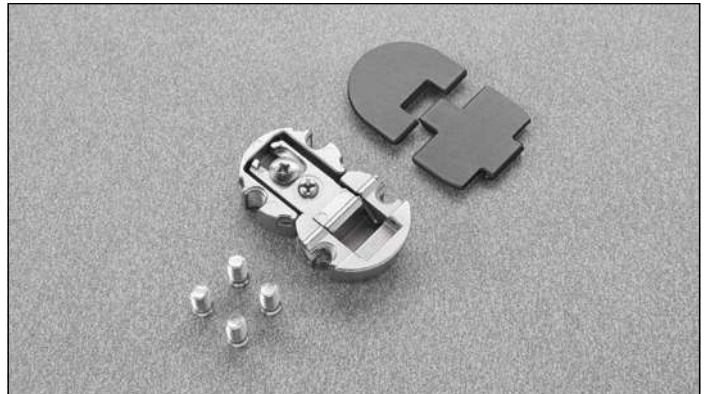





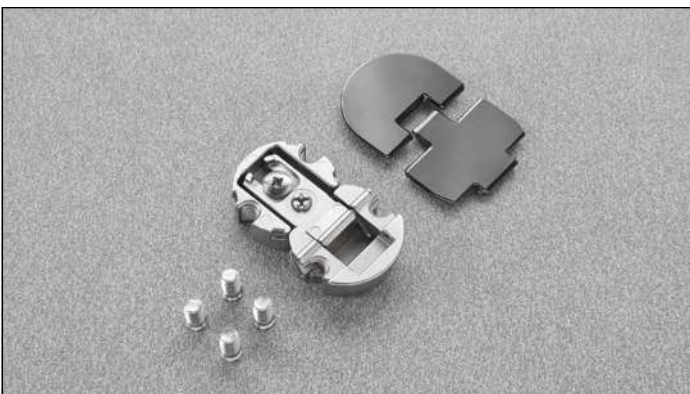

FRCK59RXXXN

Glossy metal black



Pacta

Packing - Hinges for wooden doors

Hinges	Part number	Packing	Pallet
	SPRUNG CLOSING ACTION Nickel-plated finish FRBLFEX_SN9 Smove decelerating strength  pages 22 and 23	BOX 1 hinges for right side 1 hinges for left side • 2 mounting plates • 2 Smove • Fixing screws included CARTON 8 boxes	192 cartons
	PUSH OPENING Nickel-plated finish FRBLFEP_SN9 Smove decelerating strength  pages 22 and 23		
Cover	Part number	Packing	Pallet
	SRXB78A_XXXNF Colour of the cover  Page 16	BOX 2 covers CARTON 8 boxes	192 cartons
Central hinge	Part number	Carton	Pallet
	FRCK59RXXX_ Colour of the cover cap  Page 17 Suggested for cabinets over 900 mm width	45 hinges • 45 cover caps for door • 45 cover caps for cabinet • Fixing screws included	36 cartons

Packing - Hinges for aluminium framed doors

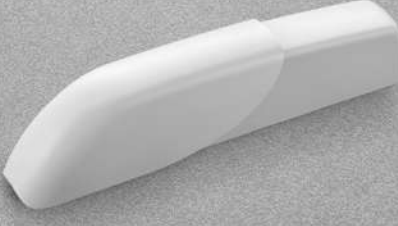
Hinges	Part number	Packing	Pallet
	<p align="center">SPRUNG CLOSING ACTION</p>	<p align="center">BOX 1 hinges for right side 1 hinges for left side • 2 mounting plates • 2 Smove • Fixing screws included</p> <p align="center">CARTON 8 boxes</p>	<p align="center">192 cartons</p>
	<p align="center">Nickel-plated finish FRBZFEX_SN9 Smove decelerating strength <input type="text"/> ↑ pages 22 and 23</p>		
	<p align="center">Titanium finish FRBZFEX_SN6 Smove decelerating strength <input type="text"/> ↑ pages 22 and 23</p>		
	<p align="center">PUSH OPENING</p>		
	<p align="center">Nickel-plated finish FRBZFEP_SN9 Smove decelerating strength <input type="text"/> ↑ pages 22 and 23</p>		
	<p align="center">Titanium finish FRBZFEP_SN6 Smove decelerating strength <input type="text"/> ↑ pages 22 and 23</p>		
	<p align="center">SRXB78A_XXXNF Colour of the cover <input type="text"/> ↑ Page 16</p>	<p align="center">BOX 2 covers</p> <p align="center">CARTON 8 boxes</p>	<p align="center">192 cartons</p>

Pacta

Accessories for aluminium frame



Corner connectors for the frame assembly of the doors and the fixing of the hinge.

Part number	Description	Packing
DRZ4BSFV04	For 48 mm aluminium frame	Boxed in bags of 25 • 4 corner connectors and assembly nickel-plated and titanium screws



Aluminium door profile.

Part number	Packing	Length
DRZ4LP300P	10 lengths in anodised aluminium	3 metres
DRZ4LP300T	10 lengths in Titanium finish	3 metres

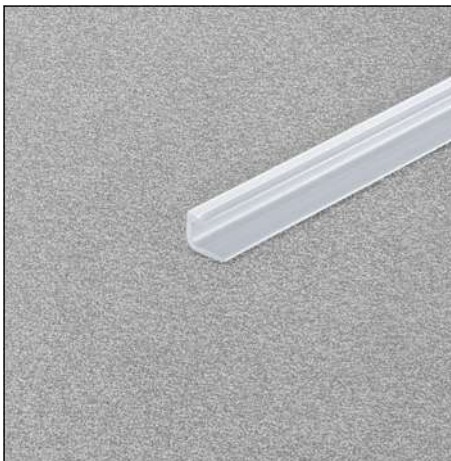

Gasket for glass.

Part number	Packing	Length
DRZXAG3000T	100 gaskets	3 metres

Assembly of aluminium framed door

D = overlay
LV = cabinet interior
L = door width
H = door height

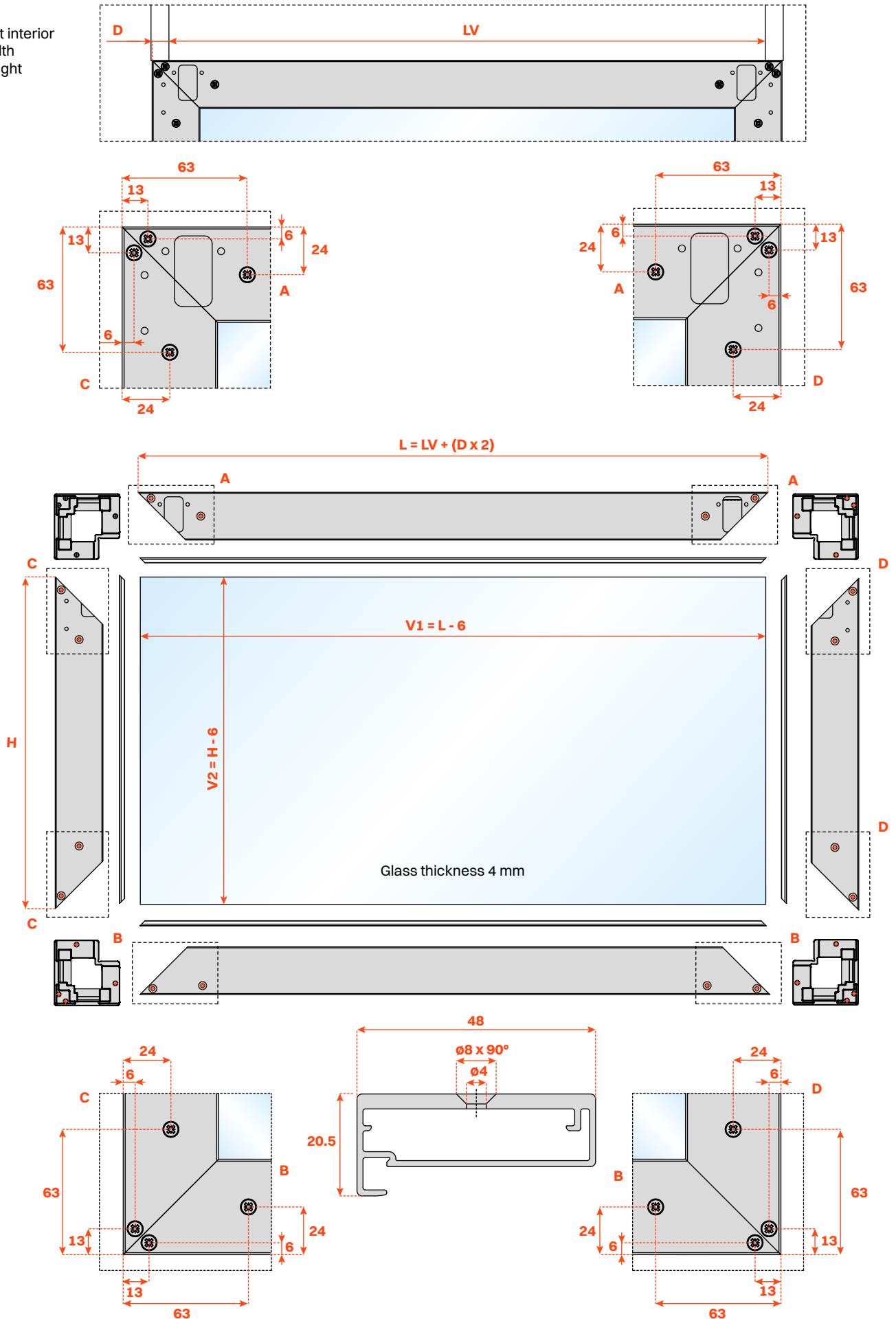

PACTA

Charts

Charts to determine which Smove is to be used for a particular door size and weight. We recommend that all applications are verified by a practical trial.

DRBWXXYXI

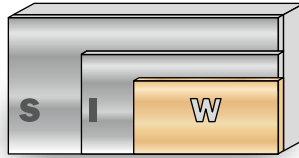

With particularly light doors, it may be sufficient to use only one Smove

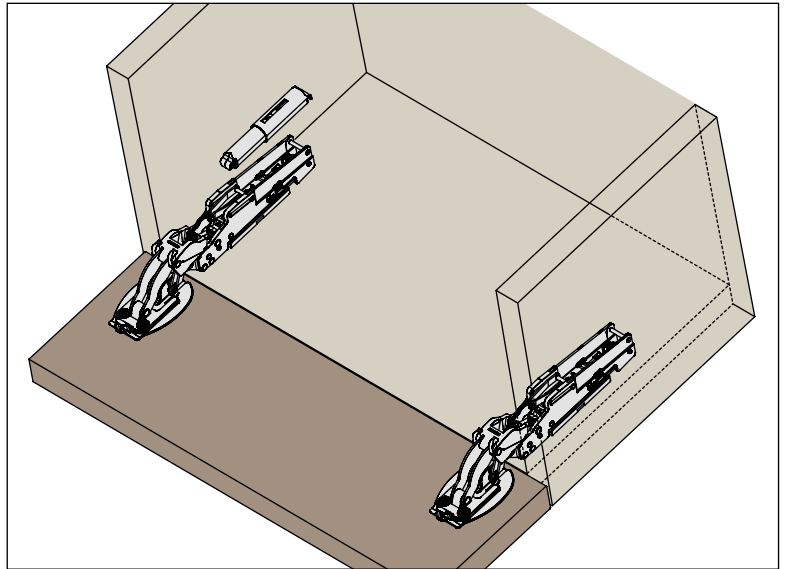
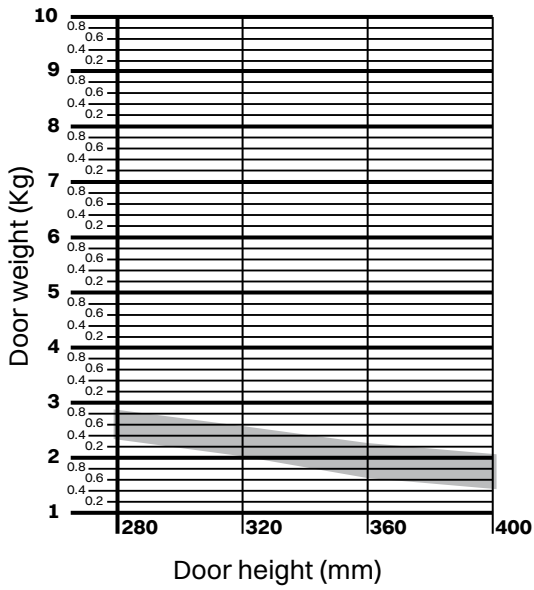

DRBWXXYXI

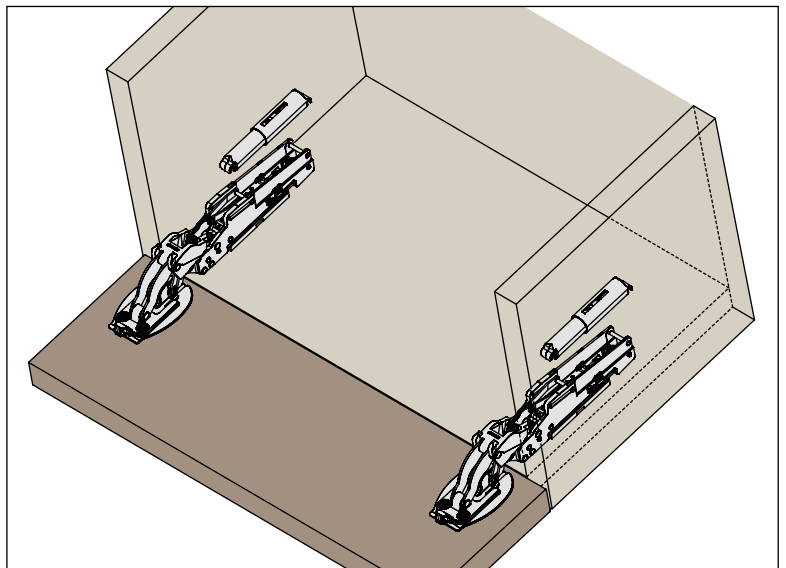
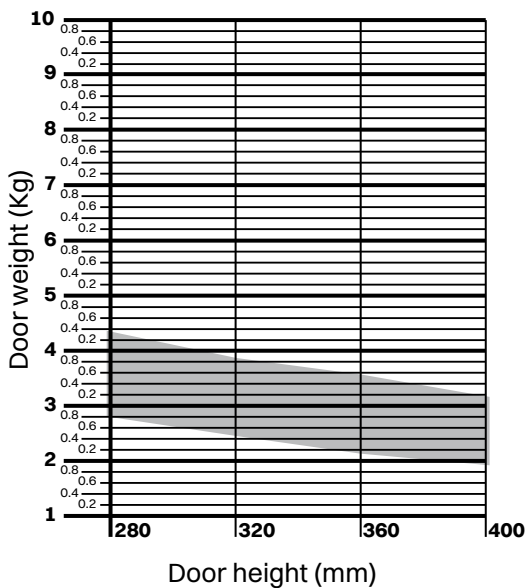

DRB|XXYXI

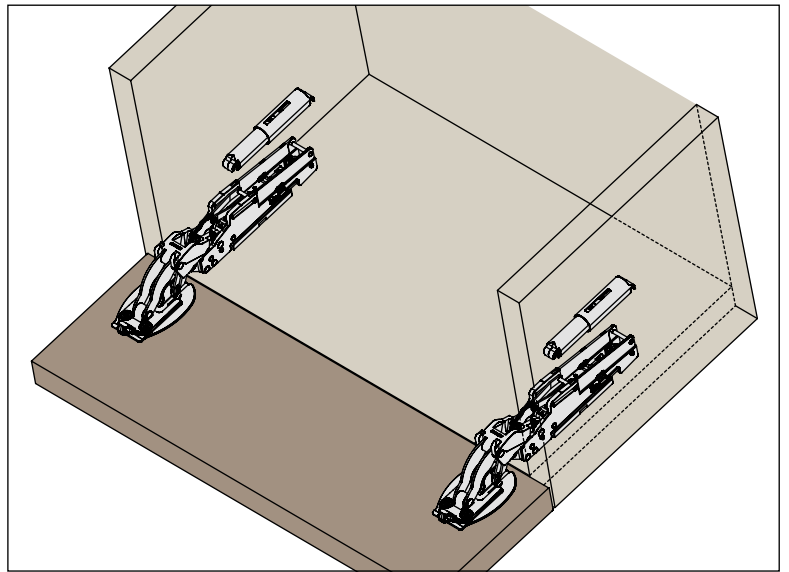
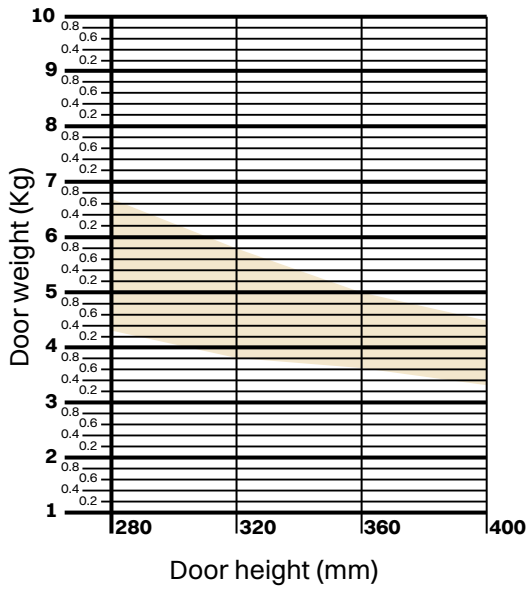
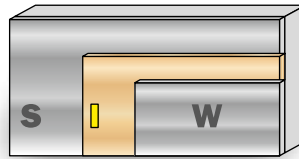

DRBSXXYXI

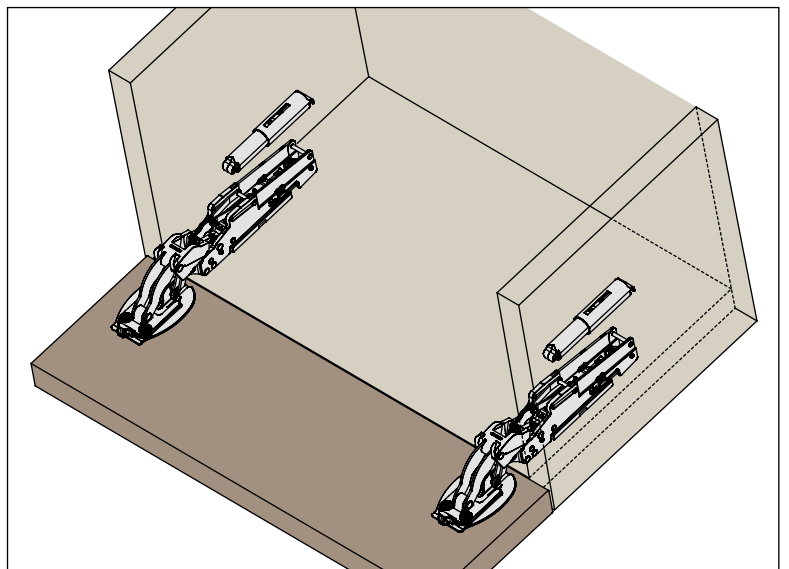
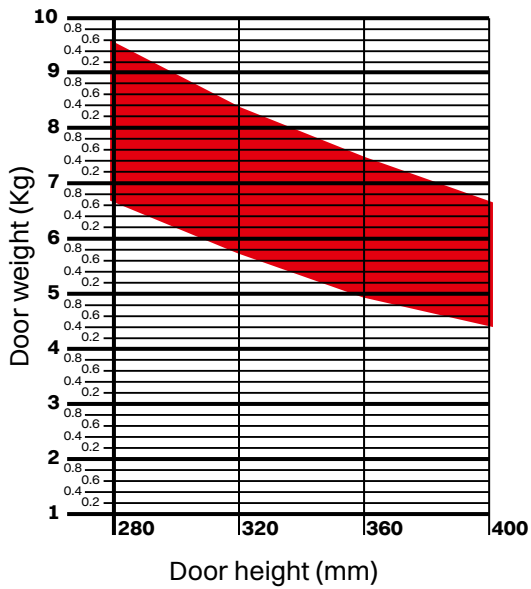
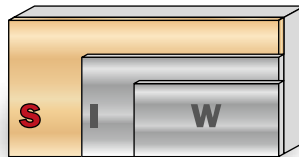





Magnetic Push

Magnetic Push

Recessed magnetic release device and retaining catches

DPMSNB - beige



DPMSNG - grey



Magnetic catch
Ø 10 mm, 40 mm length.

Packing

Boxes 250 pcs.
Cartons 1.500 pcs.

DPASNB - beige



DPASNG - grey



Optional supplementary magnetic catch to increase the holding strength. It must always be used together with the DPM. The suggested position of the DPM is the point of pressure on the door. The DPA can be positioned at any point along the opening edge of the door. Ø 10 mm, 40 mm length.

Packing

Boxes 250 pcs.
Cartons 1.500 pcs.

DP39XXG



Adjustable magnetic retaining catch.
Ø 16.6 mm.

Packing

Boxes 250 pcs.

DP28SN9



Pin-fix striker for magnetic catches.
Ø 11.5 mm.

Packing

Boxes 250 pcs.

DP38XX91



Self-adhesive striker for magnetic catches.
20x14 mm.

Packing

Boxes 250 pcs.

Release device application

Application of the release device to be recessed

Drill a hole \varnothing 10 mm and min. 40 mm depth in the top, the side or the base panel of the cabinet.
Insert the release device into the hole.

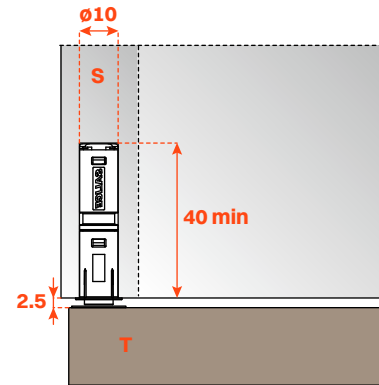

Inserted adjustable retaining catch.

The retaining catch DP39 is itself magnetic and together with the magnetism of the release device DPM considerably increase (30%) the holding strength of the door against the cabinet side, thus avoiding accidental openings.

For aluminium framed doors, we recommend using a one component polyurethane adhesive with low expansion.

For the installation it is necessary to drill a hole \varnothing 15 mm and 11 mm depth in the door.

Depth adjustment from -0.5 mm to +2.5 mm.

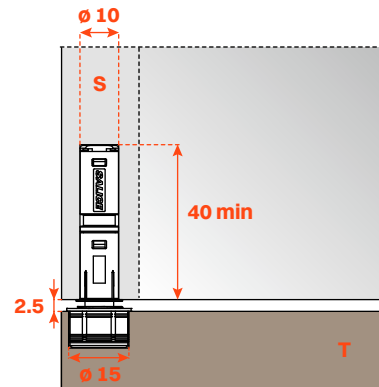

Pin-fix striker only for wooden doors

Apply the retaining catch to the magnetic release device.
Close the door.
The point of the retaining catch will show where to insert it.
Reopen the door and drive in the pin to fix in position.

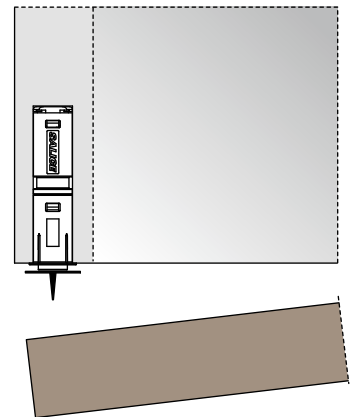

Retaining catch with adhesive strip

Apply the retaining catch to the magnetic release device. Remove the protective strip from the adhesive. Close the door. In this way the retaining catch is positioned on the door. Reopen the door and apply a firm pressure to the retaining catch to ensure a correct installation.

ATTENTION:

For a correct application and to ensure optimal endurance, we suggest these guidelines are followed:

- 1 - clean and degrease the door surface where the retaining catch is to be installed;
- 2 - remove the protective strip from the adhesive;
- 3 - place the retaining catch in position, in a place that is at room temperature $\geq 10^\circ$ and apply a firm pressure for 10-15 seconds.

After few seconds from the installation the retaining catch is suitable for the use.
After 24h the max. hold is attained.

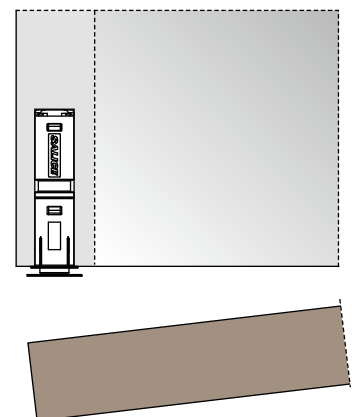

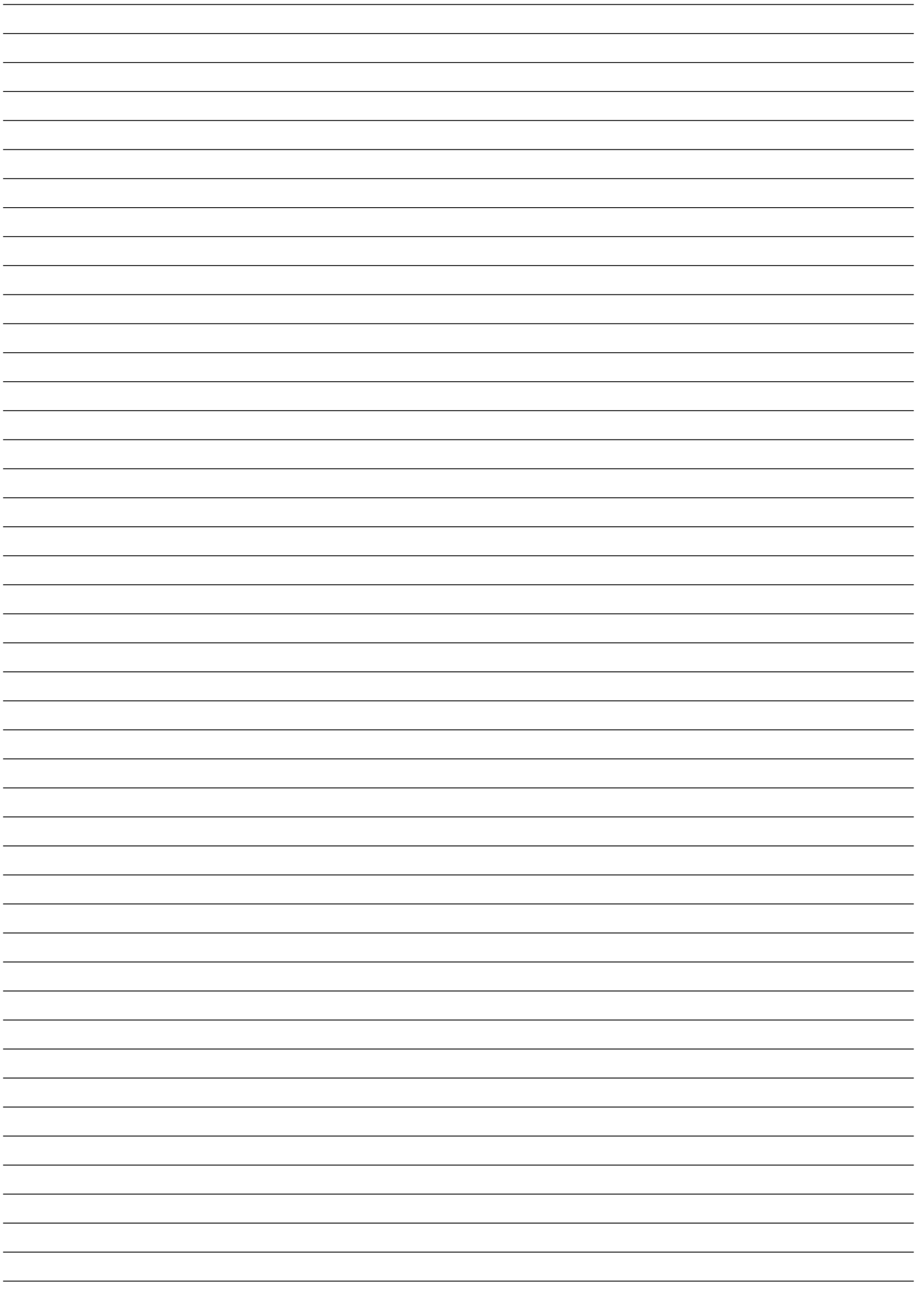

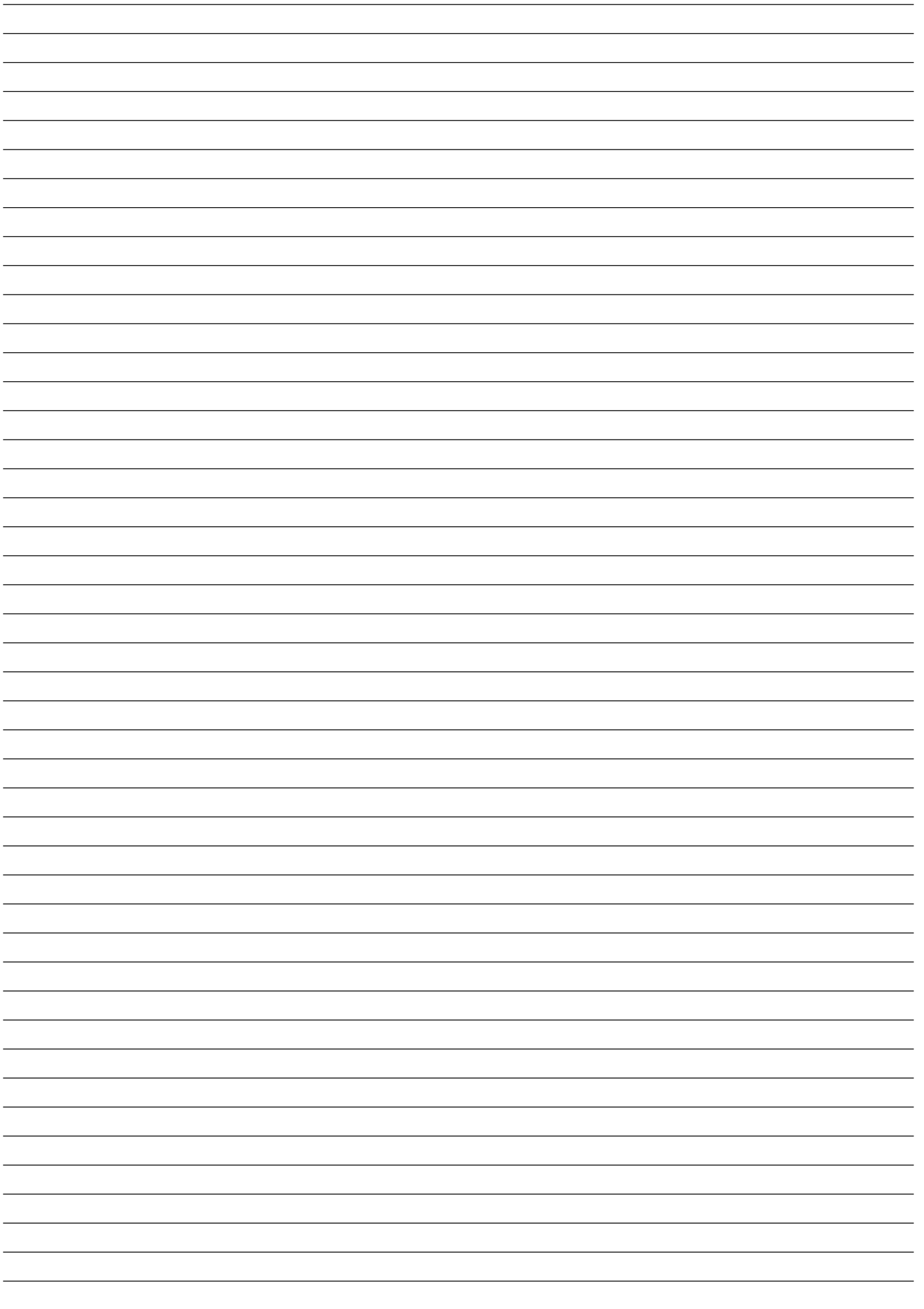

HEADQUARTERS AND PRODUCTION UNITS

ARTURO SALICE S.p.A.

HEAD OFFICE

VIA PROVINCIALE NOVEDRATESE, 10
22060 NOVEDRATE (COMO) ITALIA
TEL. 031 790424 - FAX 031 791508
info.salice@salice.com
www.salice.com

ARTURO SALICE S.p.A.

VIA ARISTIDE MERLONI, 11
61036 COLLI AL METAURO (PU) ITALIA
TEL. 0721 899800
FAX 0721 897980
info.salice@salice.com
www.salice.com

BORTOLUZZI SISTEMI S.p.A.

VIA CADUTI 14 SETTEMBRE 1944, 45
32100 BELLUNO (BL) ITALIA
TEL. 0437 930866
FAX 0437 931442
info@bortoluzzi.com
www.salice.com

NUOVA ATIM S.r.l.

VIA IV NOVEMBRE, 52
20019 SETTIMO MILANESE (MI) ITALIA
TEL. 02 33503203
FAX 02 33516514
info@atimspa.com
www.atimspa.com

VILLES S.r.l.

VIA CASTOLDI, 6/8
20090 TREZZANO SUL NAVIGLIO (MI) ITALIA
TEL. 02 4452083
FAX 02 4452838
info@villes2000.com
www.villes2000.com

BRANCHES

DEUTSCHE SALICE GMBH

RUDOLF DIESEL STR. 10
74382 NECKARWESTHEIM
TEL. 07133 9807-0
FAX. 07133 9807-16
info.salice@deutschesalice.de
www.salice.com

DEUTSCHE SALICE GMBH

VERKAUFSBÜRO NORD
RINGSTRASSE 36/A30 CENTER
32584 LÖHNE
TEL. 05731 15608-0
FAX. 05731 15608-10
vknord@deutschesalice.de
www.salice.com

SALICE UK LTD.

KINGFISHER WAY
HINCHINGBROOKE BUSINESS PARK
HUNTINGDON CAMBS PE 29 6FN
TEL. 01480 413831
FAX. 01480 451489
info.salice@saliceuk.co.uk
www.salice.com

SALICE FRANCE S.A.R.L.

285 RUE DE GOA ZAC LES 3 MOULINS
06600 ANTIBES
TEL. 0493 330069
FAX. 0493 330141
info.salice@salicefrance.com
www.salice.com

SALICE ESPAÑA, S.L.U.

C/ AIGUAFREDA 4, P.I. AMETLLA PARK
08480 L'AMETLLA DEL VALLÈS (BARCELONA)
TEL. 0034 938 46 88 61
info.salice@saliceespana.es
www.salice.com

SALICE PORTUGAL UNIP. LDA

SHOWROOM:
TV SÁ E MELO 161 FA
4470-116 MAIA - PORTO
TEL: 00351 224 154 221
Info@saliceportugal.pt
www.salice.com

ARMAZÉM:
VIA ROTA DOS MÓVEIS I 399
4585-325 GANDRA

SALICE CHINA (SHANGHAI) CO. LTD.

RM 602, 6/F, TOWER 1,
3688 YINGGANG DONG ROAD
QINGPU DISTRICT
201703 SHANGHAI, CHINA
TEL. 021 3988-9880
info.salice@salicechina.com
www.salicechina.com

SALICE INDIA PVT. LTD.

1001 & 1002, 10TH FLOOR,
CENTRUM, PLOT NO. C-3,
OPP. WAGLE PRABHAG SAMITI OFFICE,
MIDC AREA, WAGLE INDUSTRIAL ESTATE,
THANE - 400604, MAHARASHTRA
TEL. 022 20812050
info@saliceindia.com
www.salice.com

SALICE CANADA INC.

3500 RIDGEWAY DRIVE,
UNIT#1
MISSISSAUGA, ONTARIO, L5L 0B4
TEL. 905 820 8787
FAX. 905 820 7226
info.salice@salicecanada.com
www.salicecanada.com

SALICE AMERICA INC.

2123 CROWN CENTRE DRIVE
CHARLOTTE NC. 28227
TEL. 704 841 7810
FAX. 704 841 7808
info.salice@saliceamerica.com
www.saliceamerica.com

ARTURO SALICE S.p.A.

HEAD OFFICE

VIA PROVINCIALE NOVEDRATESE, 10
22060 NOVEDRATE (COMO) ITALIA
TEL. 031 790424 - FAX 031 791508

info.salice@salice.com
www.salice.com



Digital contents